

N°	REF.	DESCRIPTION	QTE.
1	001.00.00213	VIS INOX M4X15	2
2	002.00.00095	ECROU INOX M4	2
3	002.00.00140	RONDELLES DE BLOCAGE INOX $\Phi$ 4	2
4	001.50.00043	CAPOT ARRIERE INOX V50 - K50	1
5	001.00.00261	VIS INOX M4X30	2
6	001.50.00048	CAPOT AVANT INOX V50	1
7	001.50.00015	CAPOT DESSUS INOX V50 - K50	1

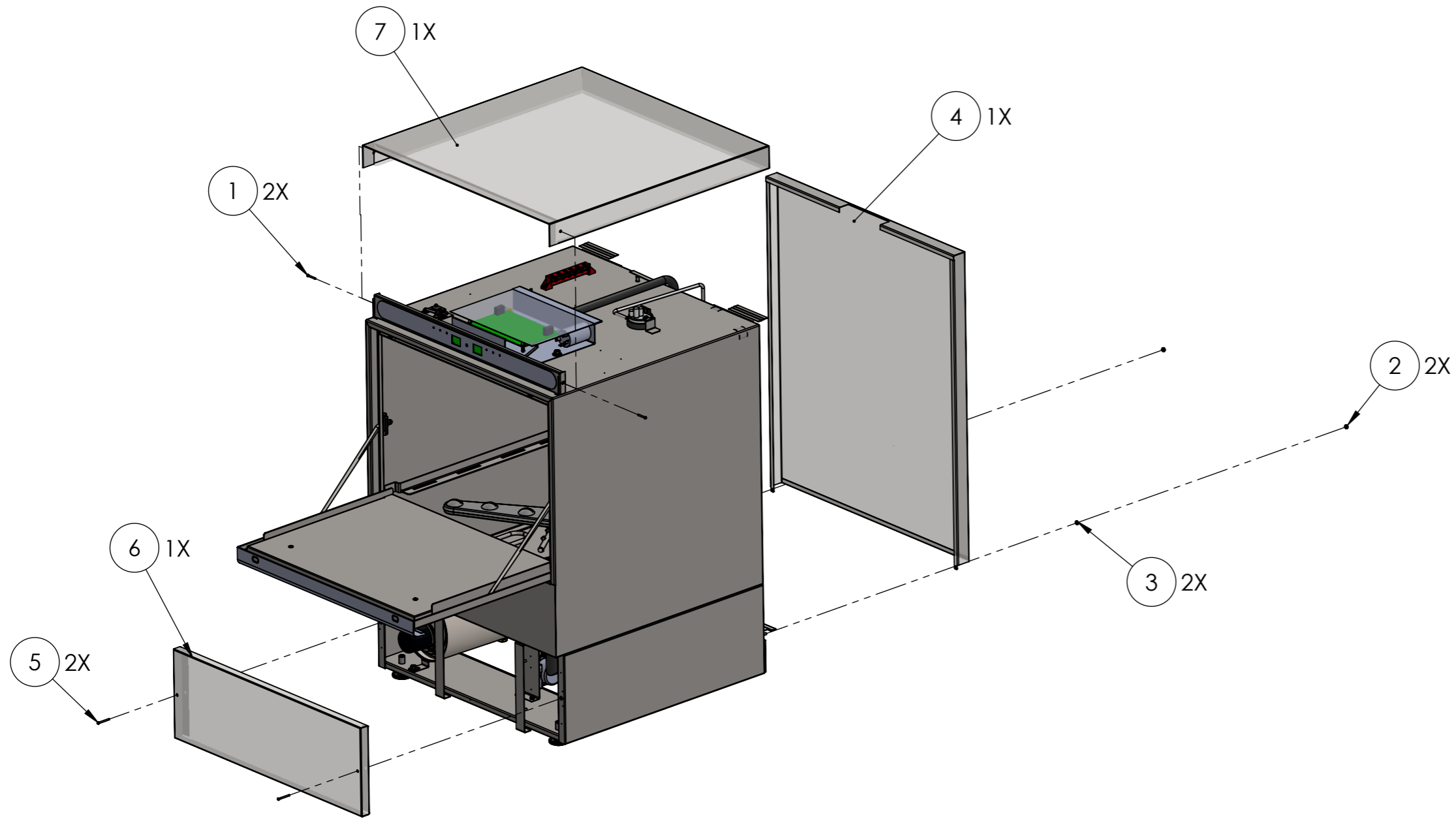

ITEM CODE:	ITEM DESCRIPTION:	
MODEL CODE: 004.50.00023	PAGE: 01	REVISION: 01

SERIES DESCRIPTION: LAVE-VAISSELLE	MODEL DESCRIPTION: D-LV50-A3P	MODEL VERSION: 220-240V 1~N 50/60 Hz
---------------------------------------	----------------------------------	---

N°	REF.	DESCRIPTION	QTE.
8	001.50.00011	PARTIE ARRIÈRE DE LA PORTE V-K	1
9	001.50.00027	PARTIE AVANT DE LA PORTE V-K	1
10	001.00.00048	AXE DE SUPPORT PORTE DROITE M6X300	1
11	001.00.00048-M	AXE DE SUPPORT PORTE GAUCHE M6X300	1
12	001.00.00221	GUIDE EN PLASTIQUE POUR L'AXE DE LA PORTE	2
13	001.00.00073	VIS INOX 2,9 X 10	4
14	001.00.00110	ECROU DOME M6	2
15	001.00.00262	VIS INOX M5X16	2

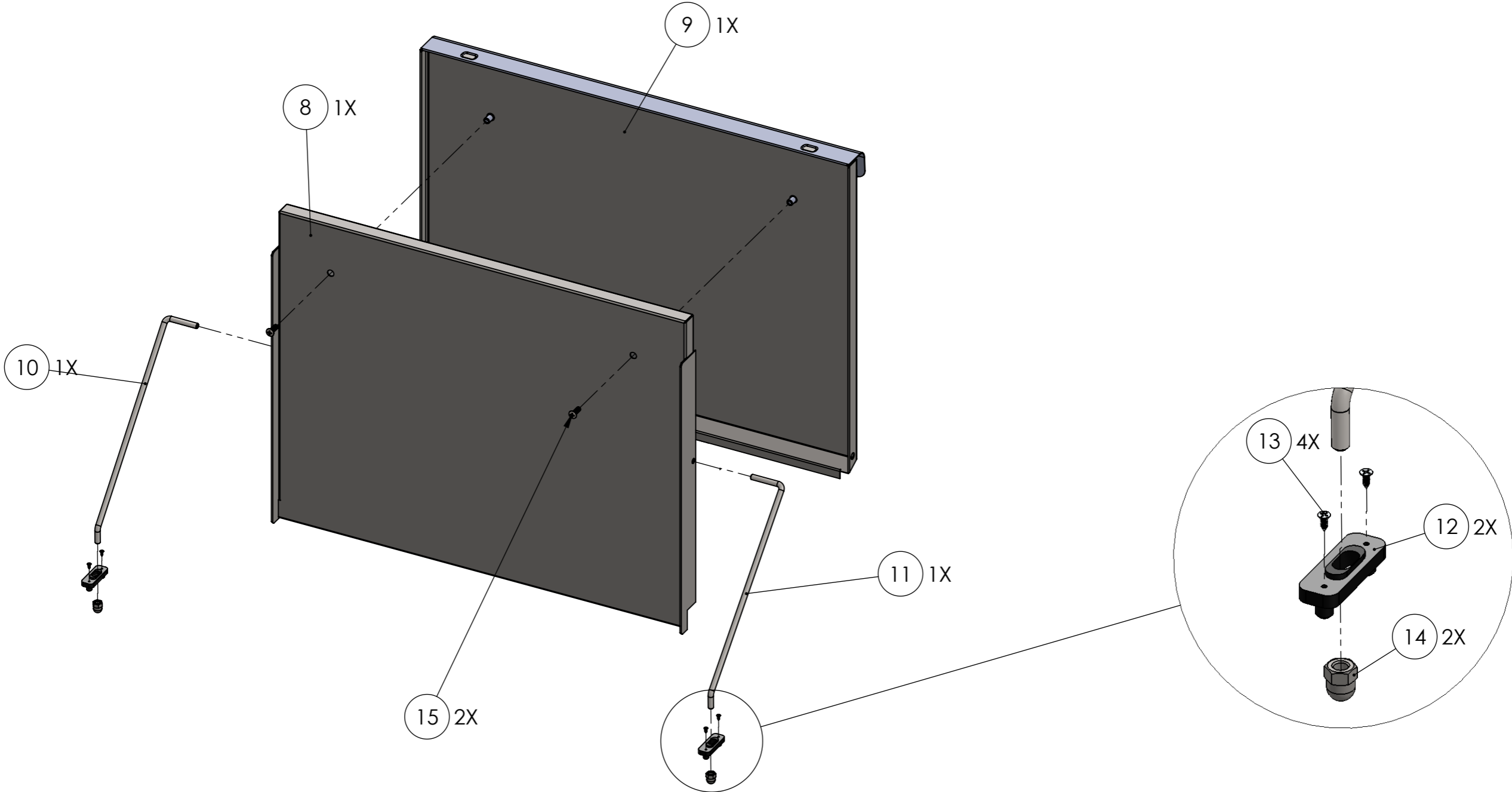

ITEM CODE: 001.50.00046	ITEM DESCRIPTION: PORTE COMPLETE 500
MODEL CODE: 004.50.00023	PAGE: 02
	REVISION: 01

SERIES DESCRIPTION: LAVE-VAISSELLE	MODEL DESCRIPTION: D-LV50-A3P	MODEL VERSION: 220-240V 1~N 50/60 Hz
---------------------------------------	----------------------------------	---

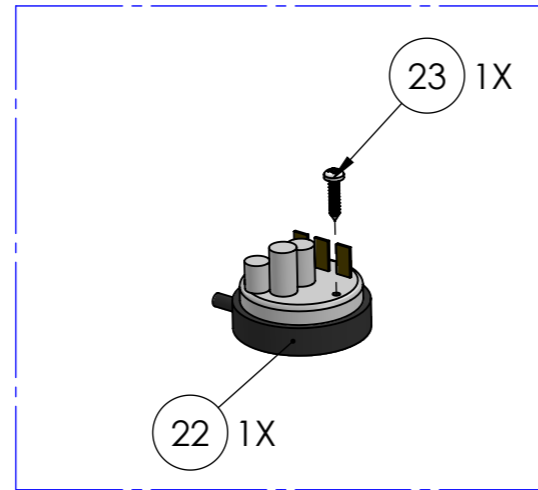
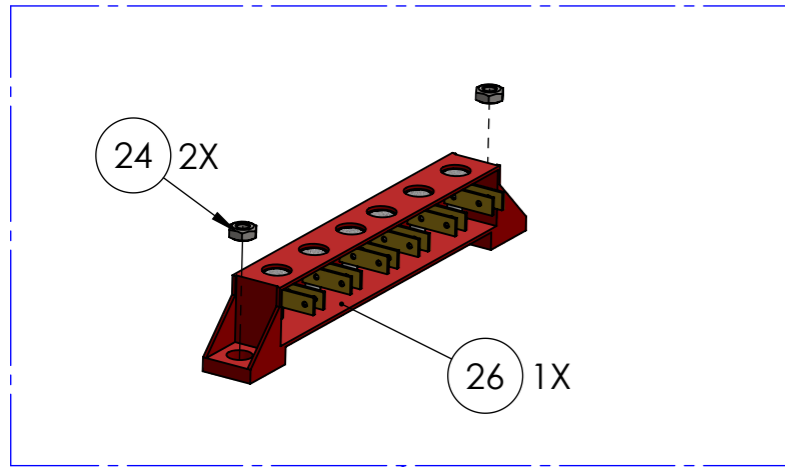

N°	REF.	DESCRIPTION	QTE.
16	003.00.00085	ENTRETOISE POUR INTERRUPTEUR DE PORTE	2
17	003.00.00041	ECROU M6 GALVANISÉ	2
18	003.00.00574	INTERRUPTEUR DE PORTE PARTIE ÉLECTRIQUE COMPLÈTE	1
19	003.00.00065	GALV. HEX. BOULON M3X16	2
20	002.00.00090	ECROU GALV. M3	2
21	003.00.00515	MICRO-INTERRUPTEUR DE PORTE 16A	1
22	003.00.00033	PRESSOSTAT	1
23	002.00.00207	VIS D'OBTURATION 4,2 X 19	1
24	003.00.00046	ECROU M4 (GALV)	2
25	001.00.00204	RONDELLE DE SÉCURITÉ GALVANISÉE 6,4x11x0,7	2
26	003.00.00030	TABLEAU D'ALIMENTATION ÉLECTRIQUE 6CON	1

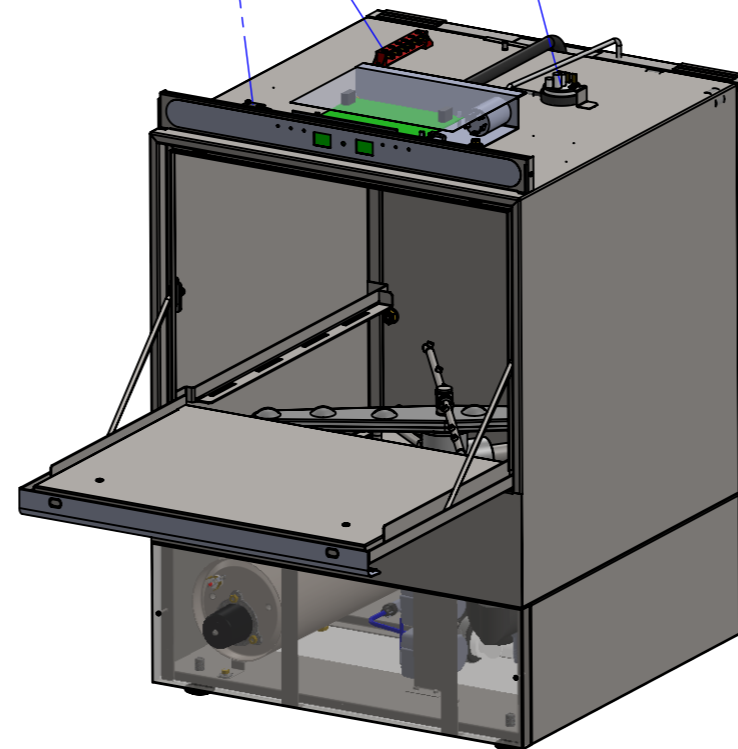
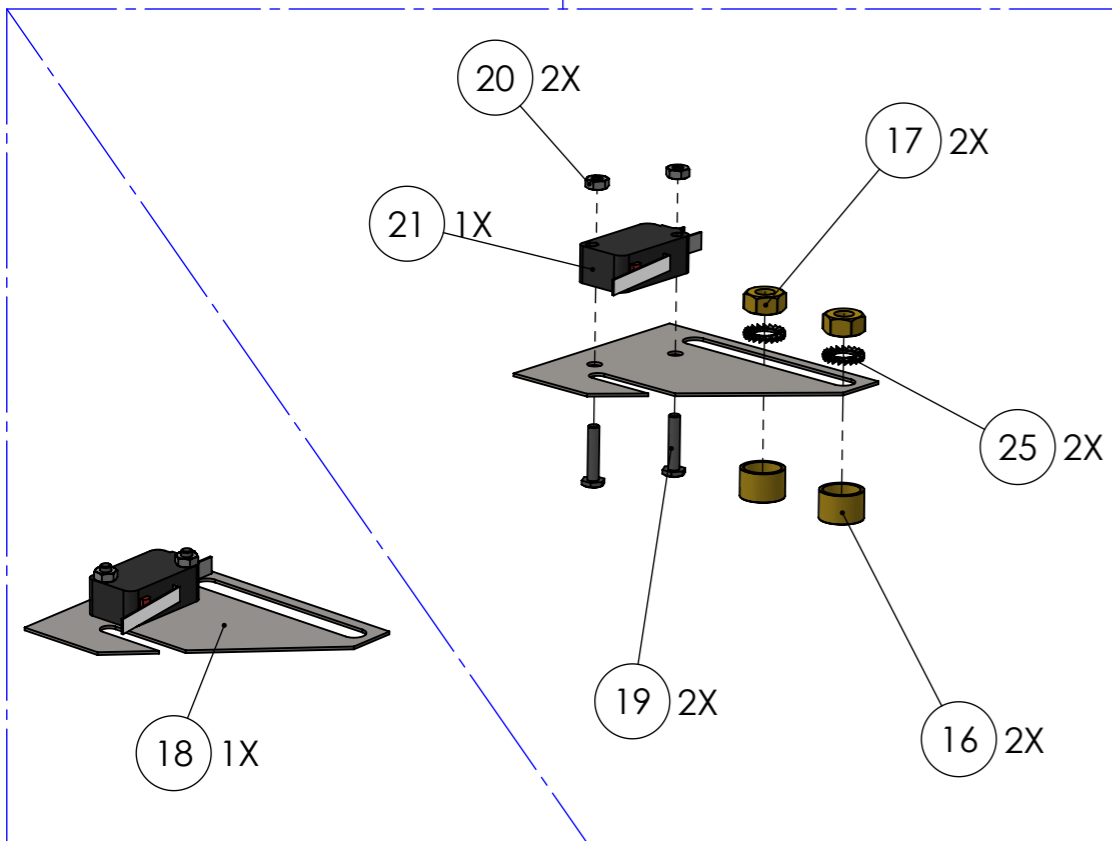

ITEM CODE:	ITEM DESCRIPTION:
MODEL CODE: 004.50.00023	PAGE: 03
	REVISION: 01

SERIES DESCRIPTION:  
LAVE-VAISSELLE

MODEL DESCRIPTION:  
D-LV50-A3P

MODEL VERSION:  
220-240V 1~N 50/60 Hz

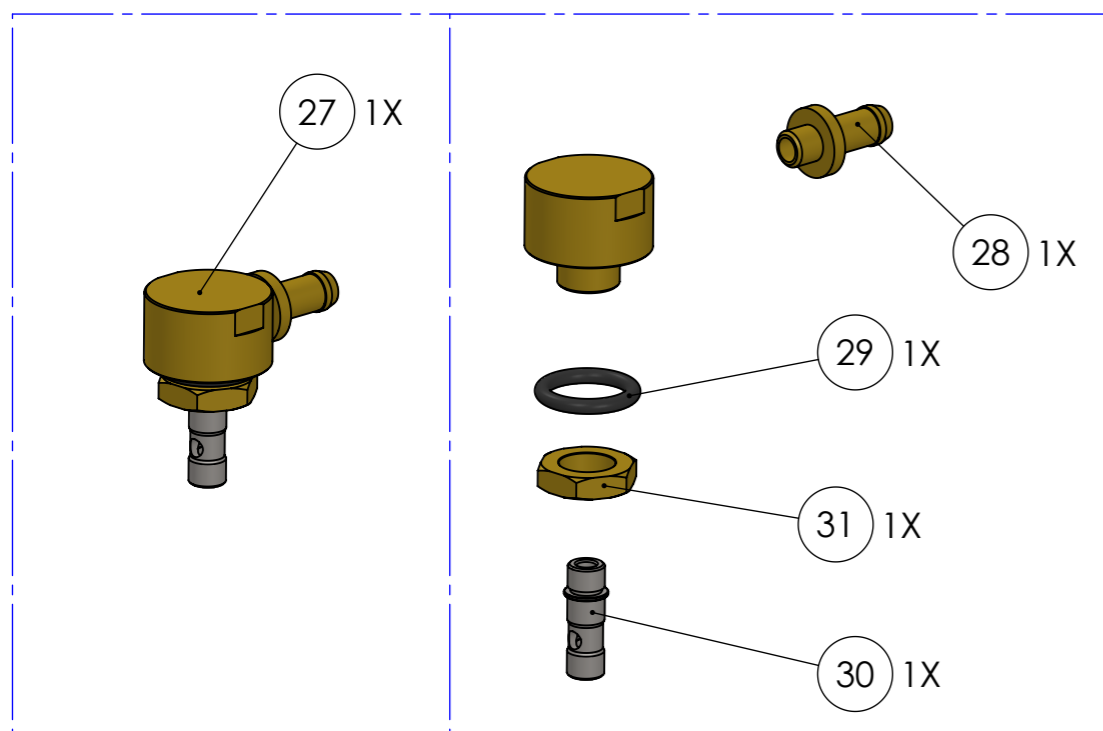

N°	REF.	DESCRIPTION	QTE.
27	002.35.00029	BASE DE RINÇAGE SUPÉRIEURE COMPLÈTE	1
28	002.00.00001	RACCORDS 1/4X10	1
29	002.00.00097	JOINT 20X4	1
30	002.50.00012	BASE DE RINÇAGE DES ESSIEUX EN INOX BL,VE,KN	1
31	002.00.00065	ECROU 3/8	1
32	003.50.00027	PANNEAU DE CONTROLÉ COMPLET A500	1
33	003.50.00036	PLATEAU DE PANNEAU COMPLET A500	1
34	001.00.00045	RONDELLE TEFLON $\Phi 12,5 \times 8 \times 2,5$	2
35	003.00.00516	RONDELLE ACIER $\Phi 6 \times 18$	2
36	001.00.00204	RONDELLE DE SERRAGE GALVA 6,4x11x0,7	2
37	003.00.00041	ECROU M6 GALVANISE	2

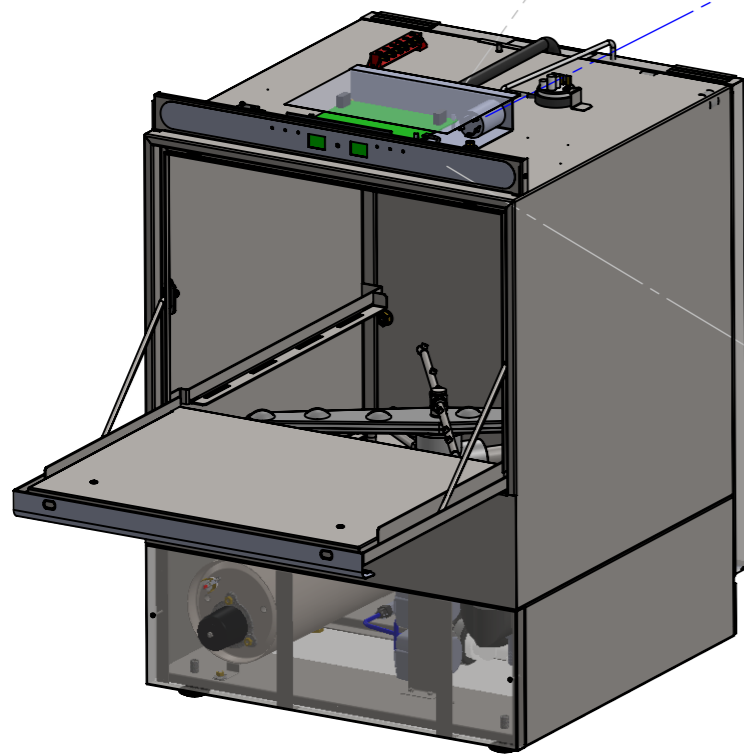
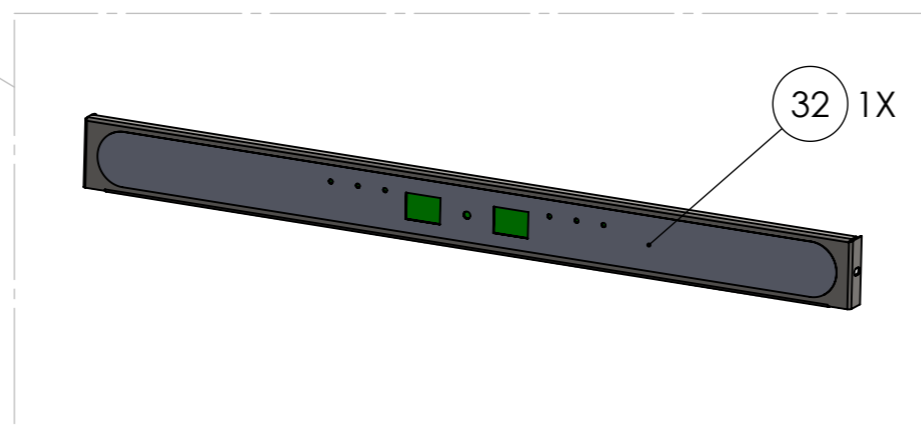
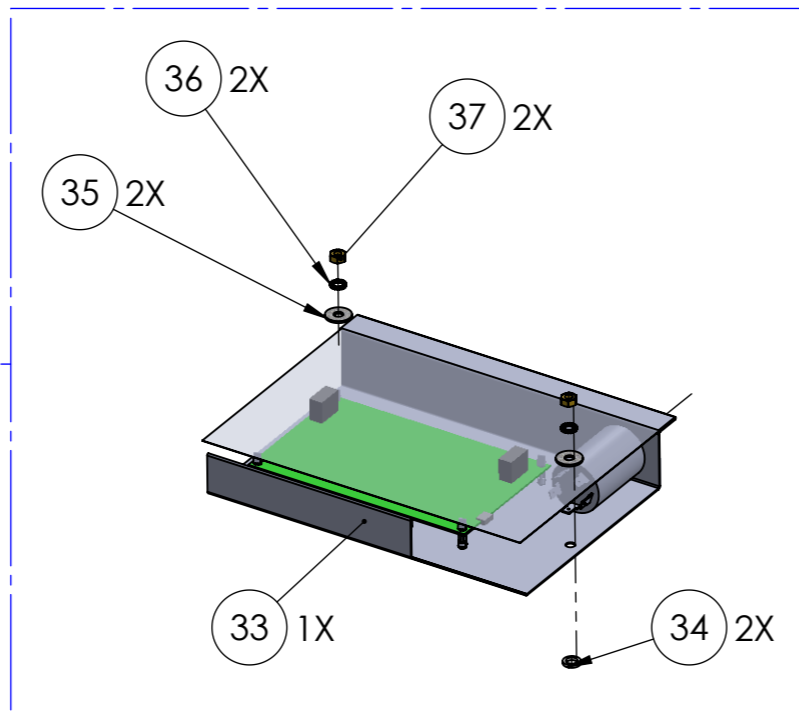

ITEM CODE:		ITEM DESCRIPTION:	
MODEL CODE:	004.50.00023	PAGE:	04
		REVISION:	01

SERIES DESCRIPTION:  
LAVE-VAISSELLE

MODEL DESCRIPTION:  
D-LV50-A3P

MODEL VERSION:  
220-240V 1~N 50/60 Hz

N°	REF.	DESCRIPTION	QTE.
38	001.50.00044	PANNEAU D'INTERRUPTEURS INOX V50	1
39	003.00.00609	INTERFACE UTILISATEUR 7 SEGM. VERSION AFFICHEUR	1
40	003.50.00026	ADHESIF POUR A500 (LCD)	1
41	002.00.00090	GALV. ECROU M3	4

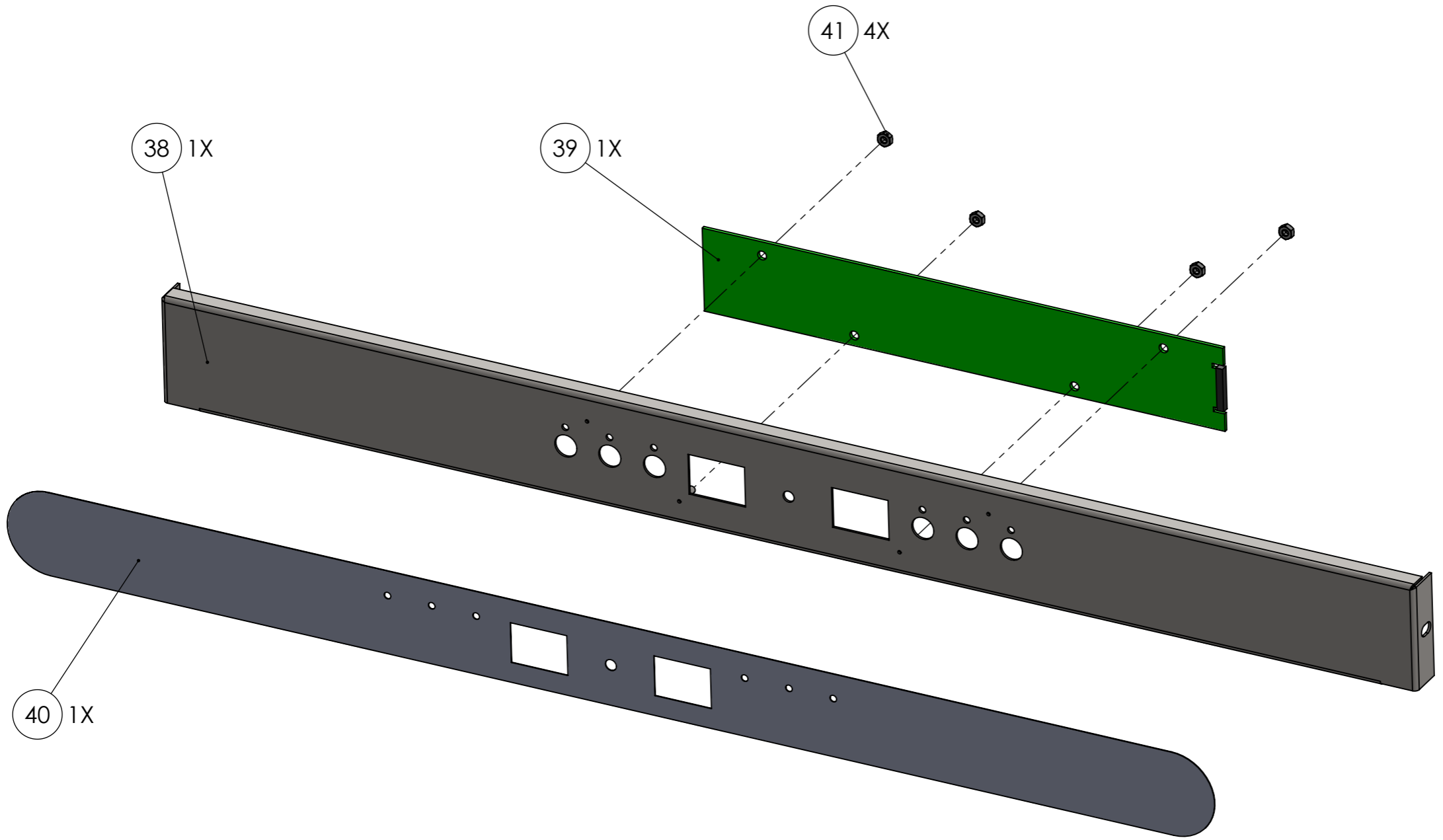

ITEM CODE: 003.50.00027		ITEM DESCRIPTION: PANNEAU DE CONTRÔLE COMPLET A500	
MODEL CODE: 004.50.00023	PAGE: 05	REVISION: 01	

SERIES DESCRIPTION: LAVE-VAISSELLE	MODEL DESCRIPTION: D-LV50-A3P	MODEL VERSION: 220-240V 1~N 50/60 Hz
---------------------------------------	----------------------------------	---

N°	REF.	DESCRIPTION	QTE.
42	001.50.00083	BASE PLATEAU NOX A500	1
43	003.00.00625	FILTRE ÉLECTROMAGNÉTIQUE 250V 50/60Hz 10A 40°C	1
44	003.00.00630	ENTRETOISE PCB RC-12 PLASTIQUE	4
45	003.00.00607	VERSION DU TABLEAU PRINCIPAL DE L'ATLAS	1
46	003.50.00037	COUVERCLE PP POUR PANNEAU A500	1
47	003.00.00610-1	CABLE CONNECTION ATLAS 500mm	1

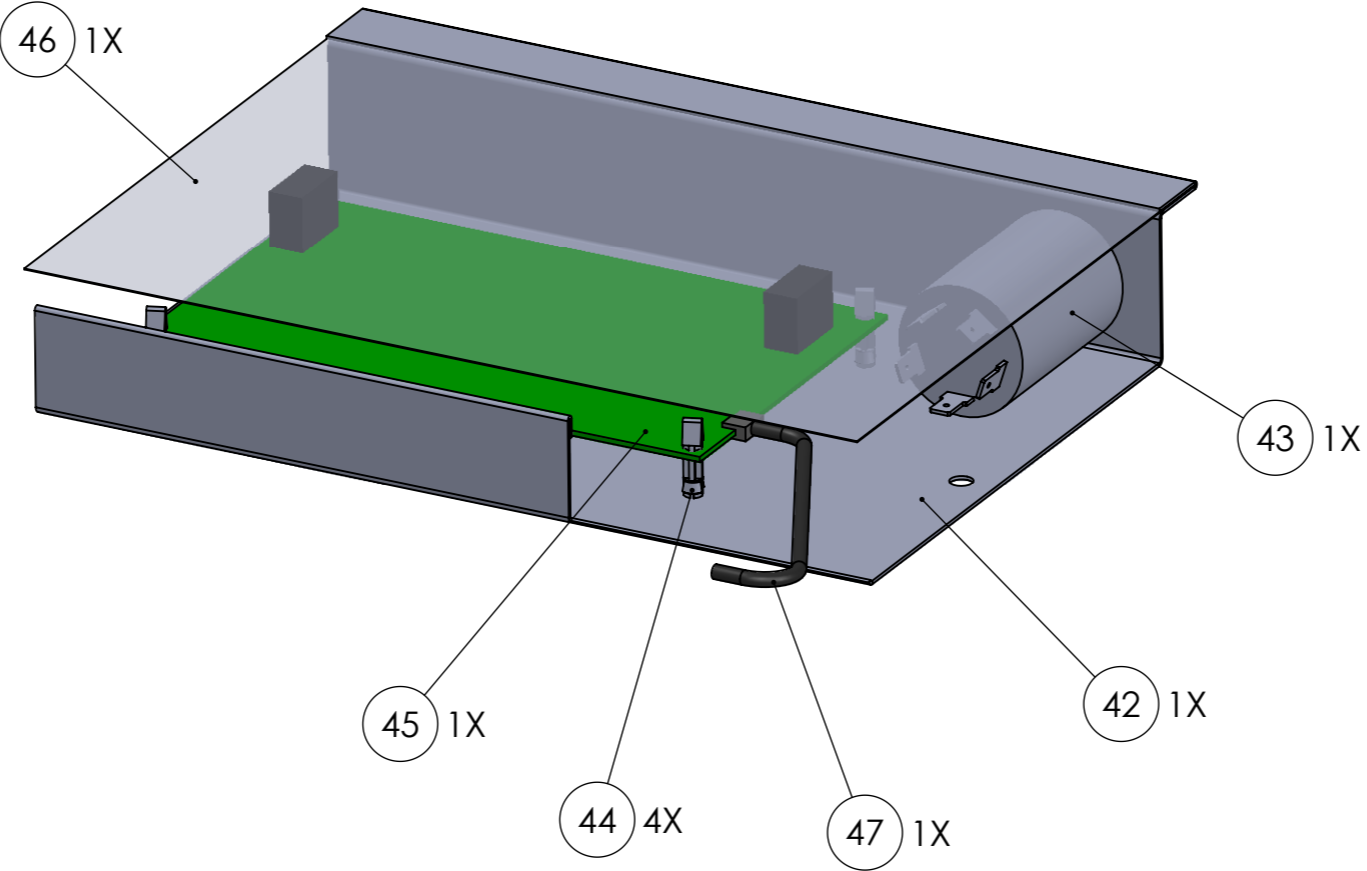

ITEM CODE: 003.50.00036	ITEM DESCRIPTION: PANNEAU DE CONTRÔLE COMPLET A500	
MODEL CODE: 004.50.00023	PAGE: 06	REVISION: 01

SERIES DESCRIPTION: LAVE-VAISSELLE	MODEL DESCRIPTION: D-LV50-A3P	MODEL VERSION: 220-240V 1~N 50/60 Hz
---------------------------------------	----------------------------------	---

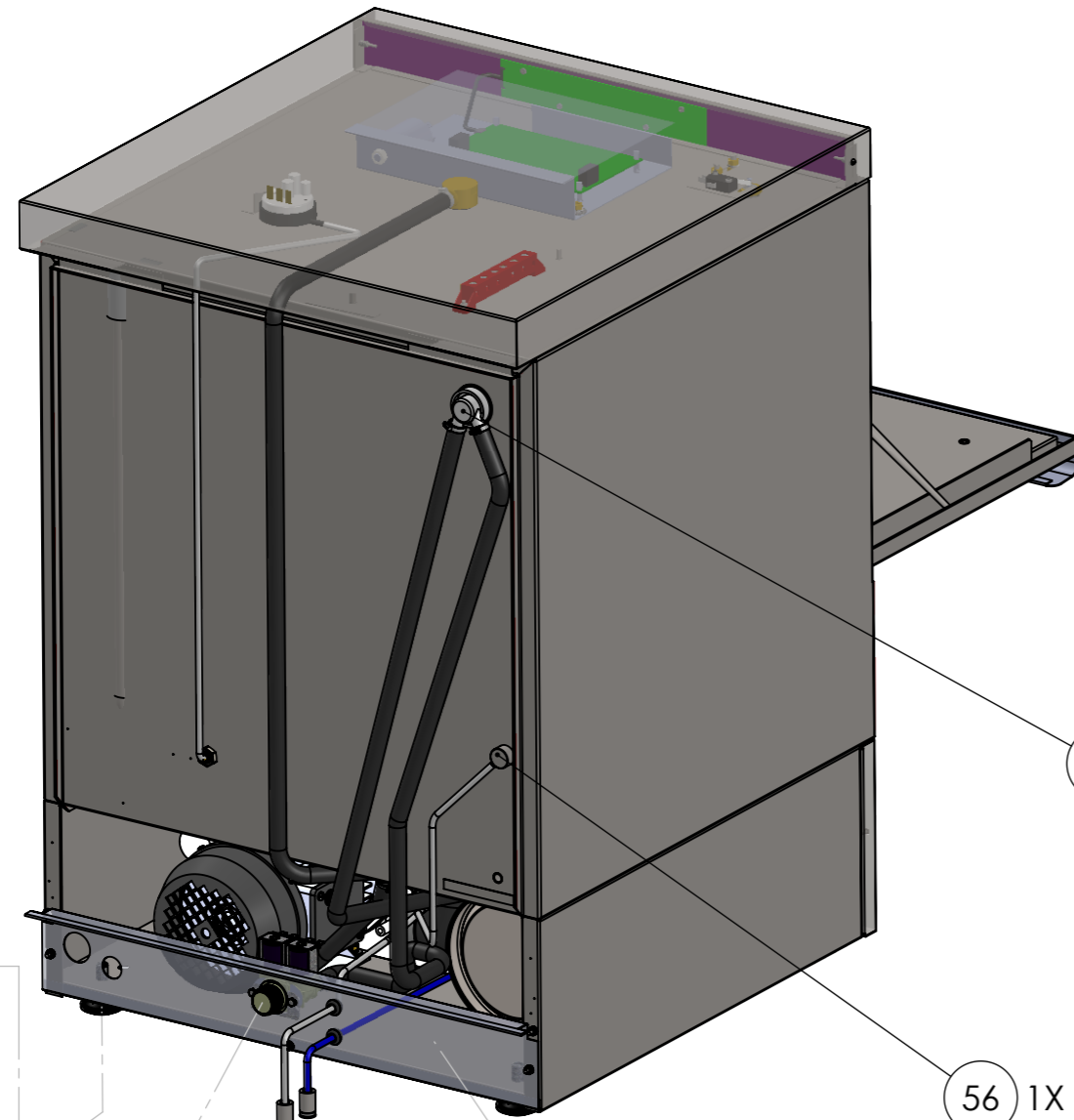

N°	REF.	DESCRIPTION	QTE.
48	002.00.00095	INOX ECROU M4	3
49	002.00.00140	RONDELLE SERRAGE INOX $\Phi$ 4	3
50	001.00.00016	PETIT PIED NOIR M10	4
51	001.50.00072	COUVERTURE ARRIÈRE INFÉRIEURE EN INOX	1
52	003.00.00025	PROTECTEUR DE CÂBLE EN CAOUTCHOUC	2
53	003.00.00278	GALV. BOULON M4X10	2
54	003.00.00151	Valve d'entrée d'eau double	1
55	003.00.00269	VALVE DE ANTI-RETOUR (DVGW)	1
56	002.00.00233	INJECTEUR DE RÉSERVOIR DE DÉTERGENT	1

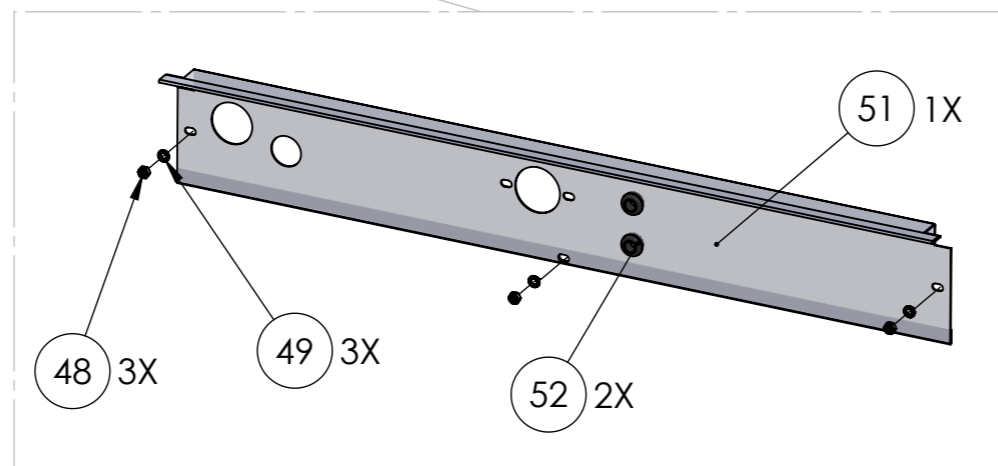
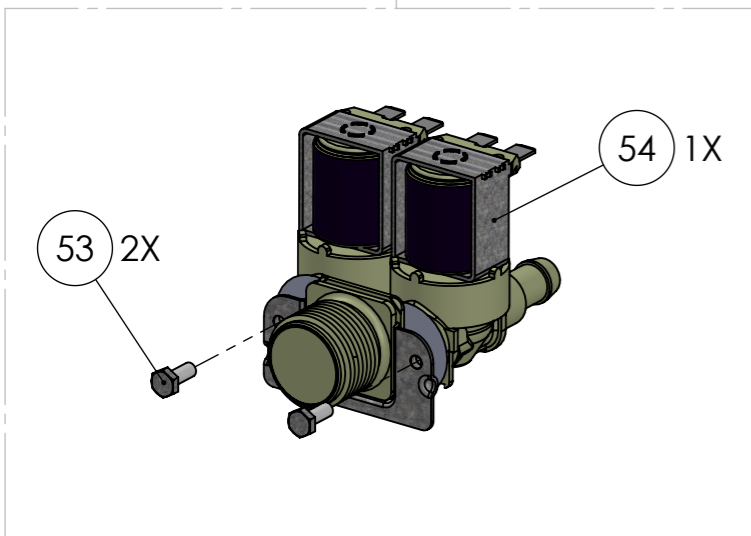
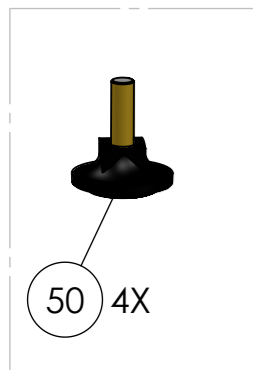

SERIES DESCRIPTION:  
LAVE-VAISSELLE

MODEL DESCRIPTION:  
D-LV50-A3P

MODEL VERSION:  
220-240V 1~N 50/60 Hz

ITEM CODE:

ITEM DESCRIPTION:

MODEL CODE:  
004.50.00023

PAGE:  
07

REVISION:  
01

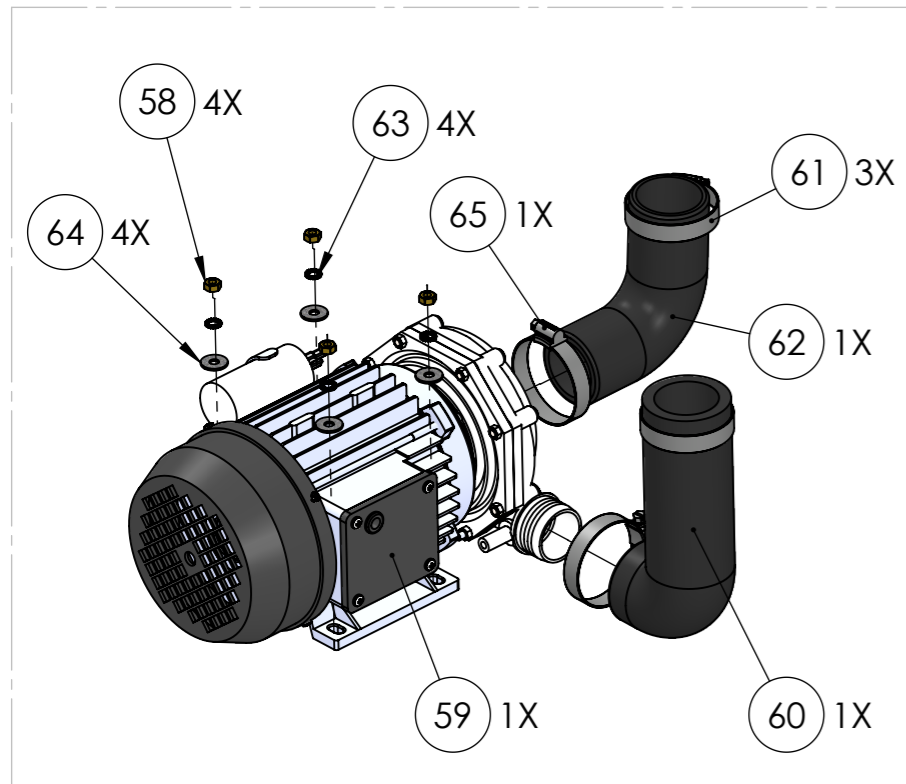

N°	REF.	DESCRIPTION	QTE.
57	006.50.00001	SURCHAUFFEUR COMPLET AVEC CHAUFFEUR ELEM. V500	1
58	003.00.00041	ECROU M6 GALVA	5
59	003.00.00350	POMPE 0,75Hp 50Hz 230V IP44	1
60	002.50.00032-1	TUYAU POMPE DE LAVAGE (SORTIE)	1
61	002.00.00050	SERRE-JOINT 40-60	3
62	002.00.00127-1	TUYAU POMPE DE LAVAGE (ENTREE)	1
63	001.00.00204	RONDELLE D'ARRET GALVA 6,4x11x0,7	5
64	003.00.00516	RONDELLE ACIER $\Phi$ 6X18	5
65	002.00.00049	SERRE-JOINT 35-50	1

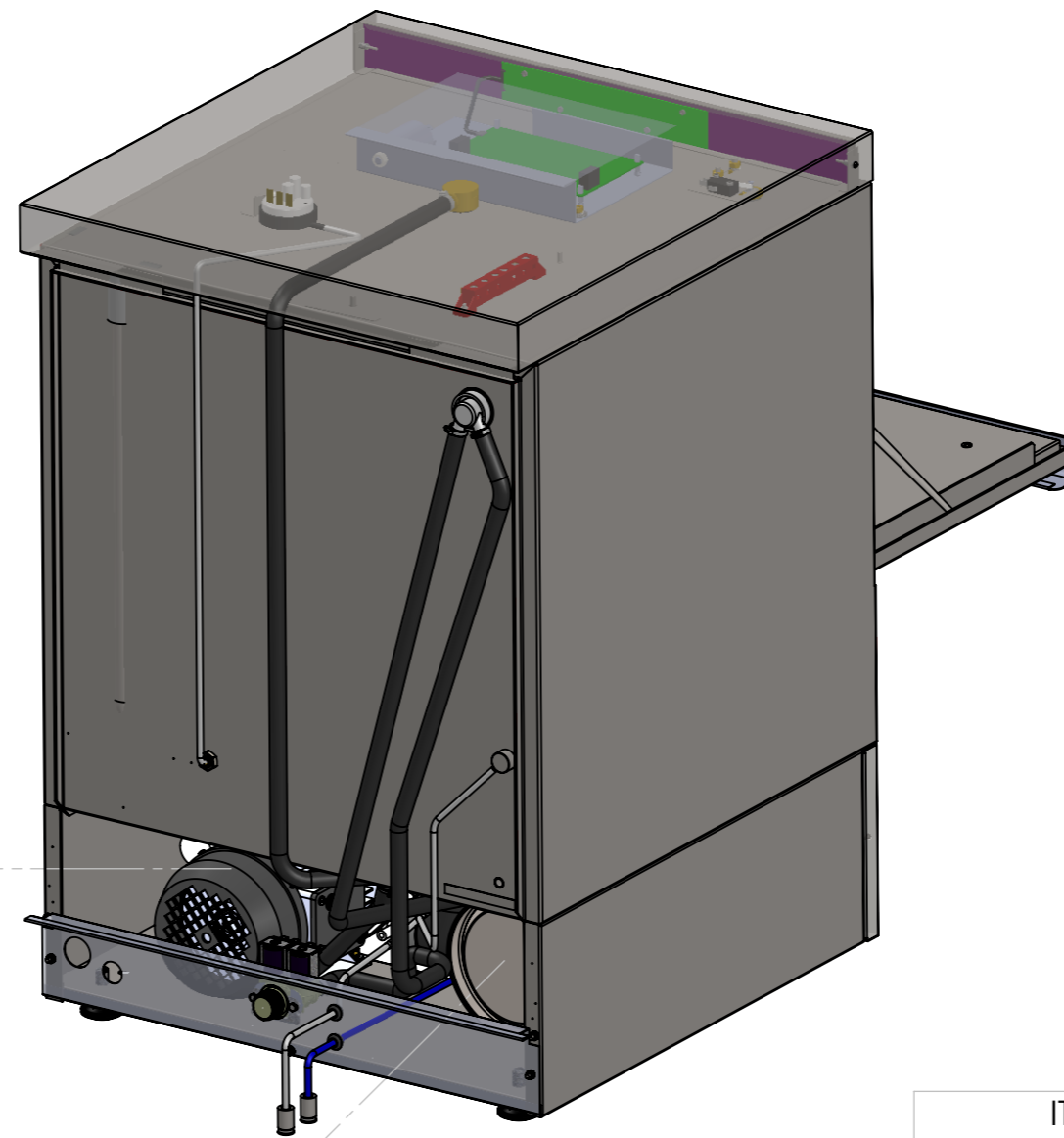
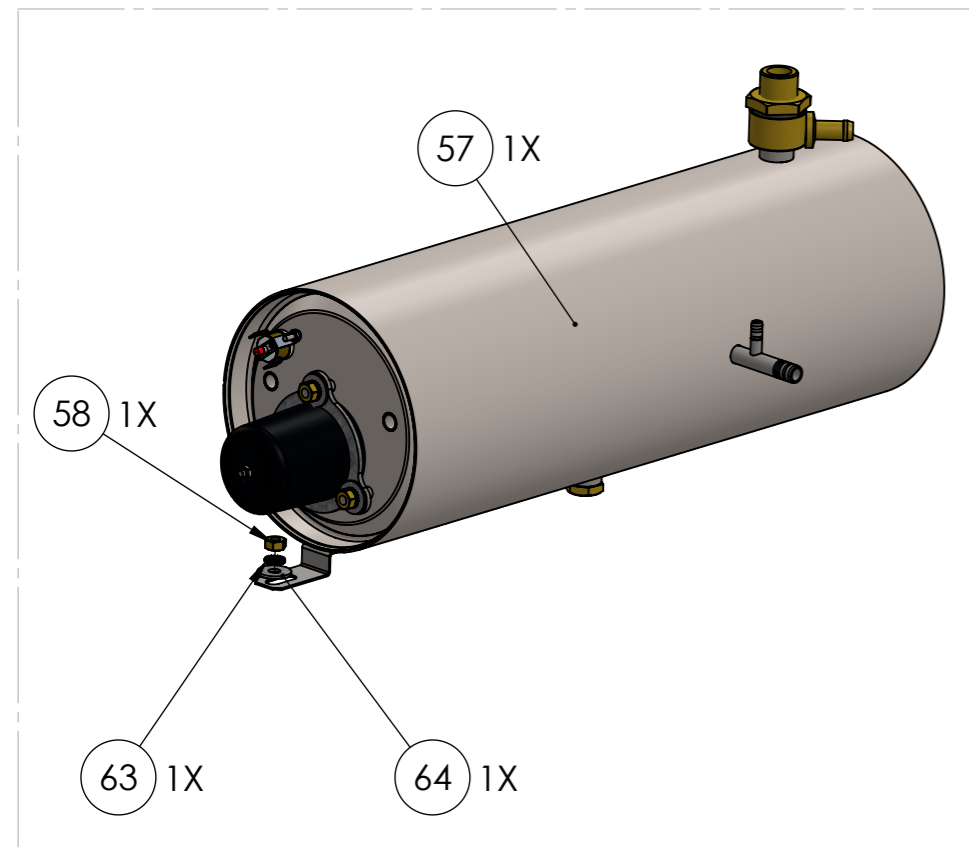

ITEM CODE:	ITEM DESCRIPTION:
MODEL CODE: 004.50.00023	PAGE: 08
	REVISION: 01

SERIES DESCRIPTION:  
LAVE-VAISSELLE

MODEL DESCRIPTION:  
D-LV50-A3P

MODEL VERSION:  
220-240V 1~N 50/60 Hz



N°	REF.	DESCRIPTION	QTE.
66	001.50.00017	SURCHAUFFEUR V500 Ø140X400	1
67	002.50.00001	BASE SORTIE SURCHAUFFEUR V500	1
68	002.00.00001	RACCORDS 1/4X10	1
69	002.00.00097	JOINT 20X4	1
70	002.00.00076	BOUCHON FILETÉ DE VIDANGE DU SURCHAUFFEUR	1
71	003.00.00260	BASE DE MONTAGE DES ÉLÉMENTS DU SURCHAUFFEUR	1
72	003.50.00005	ELEM. CHAUFFANT SURCHAUFFEUR 3kW / 230V / V-K	1
73	003.00.00516	RONDELLE ACIER Ø6X18	3
74	003.00.00041	ECROU M6 GALVA	3
75	003.00.00180	THERMOFUSIBLE DE SURCHAUFFEUR 105°C	1
76	002.00.00090	GALV. ECROU M3	2
77	001.00.00204	RONDELLE DE SERRAGE GALVA 6,4x11x0,7	3
78	003.00.00004	COUVERCLE ÉLÉMENT CHAUFFANT	1
79	002.00.00150	SUPPORTS EN CÉRAMIQUE	1
80	002.00.00062	ECROU 1/2	1

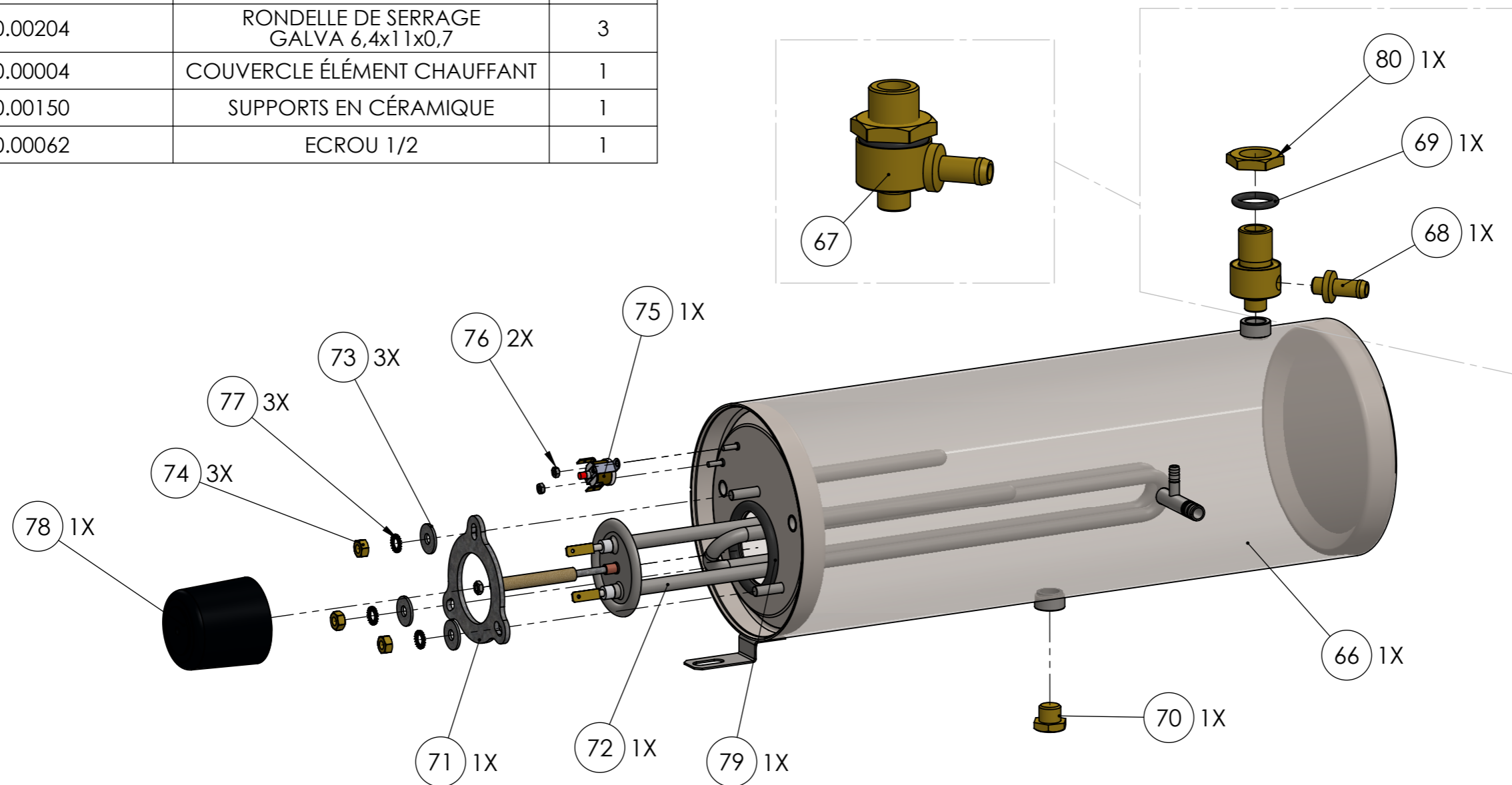

ITEM CODE:  
006.50.00001

ITEM DESCRIPTION:  
SURCHAUFFEUR COMPLET  
AVEC CHAUFFAGE ELEM. V500

SERIES DESCRIPTION:  
LAVE-VAISSELLE

MODEL DESCRIPTION:  
D-LV50-A3P

MODEL VERSION:  
220-240V 1~N 50/60 Hz

MODEL CODE:  
004.50.00023

PAGE:  
09

REVISION:  
01

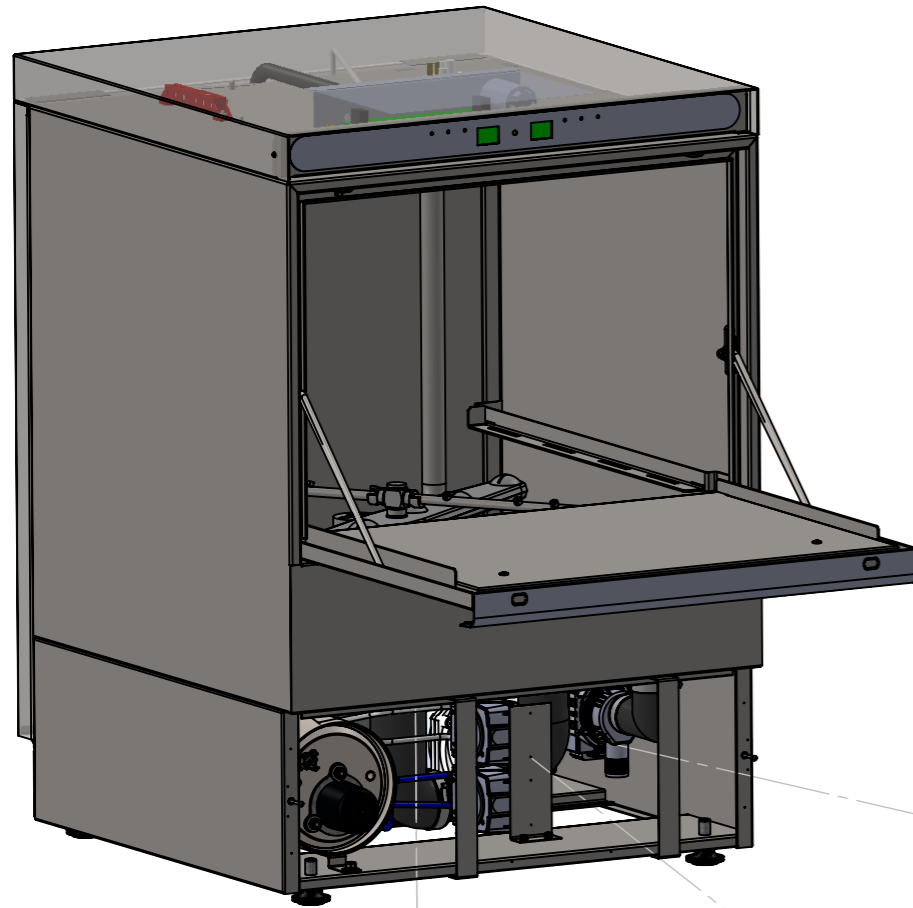

N°	REF.	DESCRIPTION	QTE.
81	003.00.00168	RÉSERVOIR THERMOFUSIBLE 90C	1
82	002.00.00090	ECROU GALV. M3	2
83	001.50.00065	BASE EN INOX POUR LA POMPE DE VIDANGE V500	1
84	002.00.00140	RONDELLE DE SERRAGE INOX $\Phi$ 4	8
85	003.00.00046	ECROU M4 (GALV)	4
86	003.00.00184	POMPE DE VIDANGE DE RÉSERVOIR 230V / 65W	1
87	002.50.00014	TUYAU D'ENTRÉE DE LA POMPE DE VIDANGE V500	1
88	002.00.00048	SERRE-JOINT 25-40	2
89	003.00.00485	M6 BOULON GALVANISE	2
90	001.50.00078	SUPPORT POUR DEUX POMPES PÉRISTALTIQUES V500	1
91	003.00.00433	POMPE D'AIDE AU RINÇAGE PÉRISTALTIQUE G302 / 230V	1
92	003.00.00429	POMPE À DÉTERGENT PÉRISTALTIQUE G300 / 230V	1
93	002.00.00095	ECROU INOX M4	4

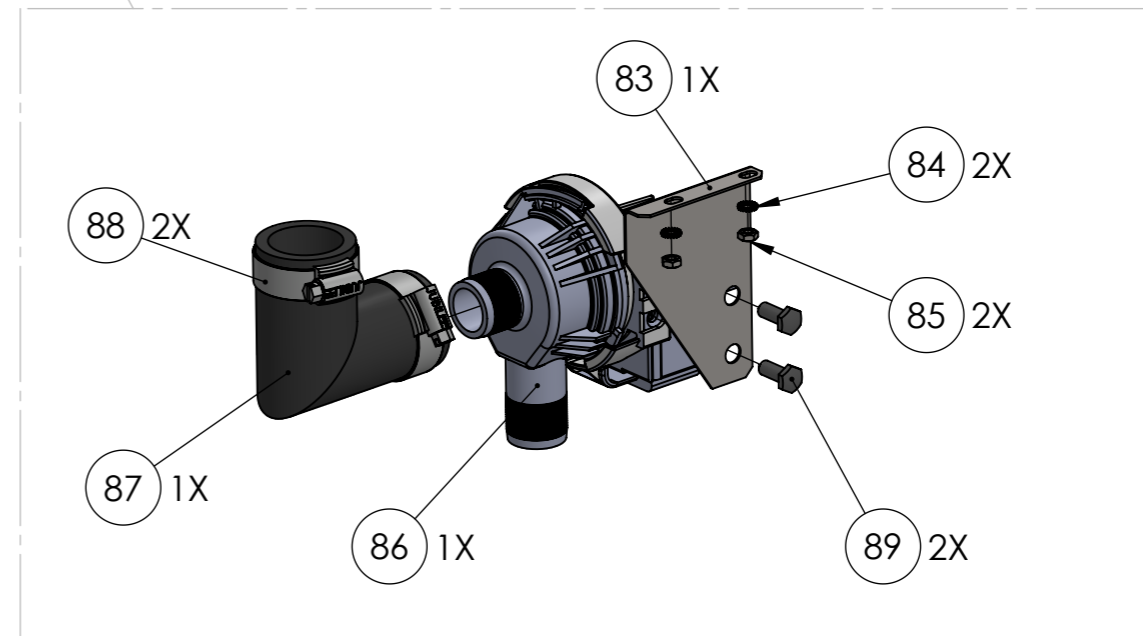
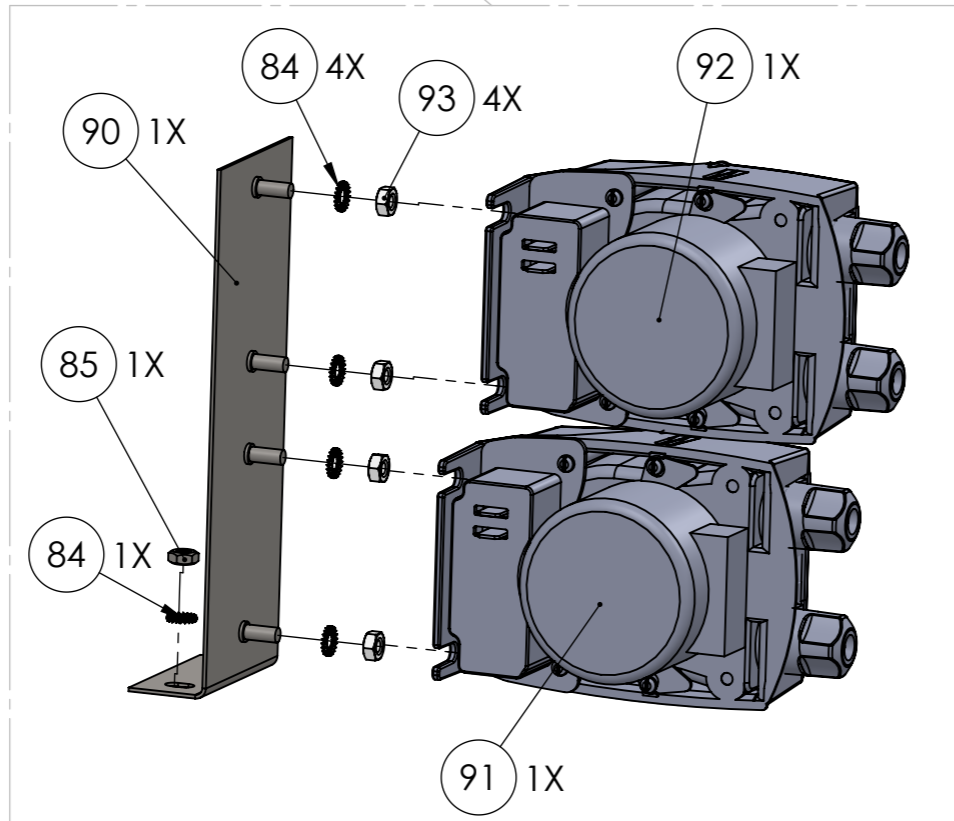
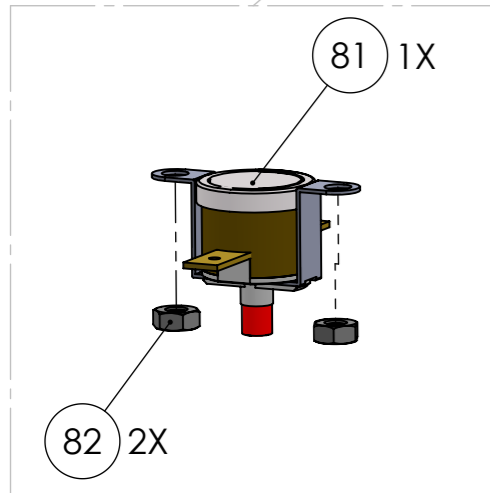

SERIES DESCRIPTION:  
LAVE-VAISSELLE

MODEL DESCRIPTION:  
D-LV50-A3P

MODEL VERSION:  
220-240V 1~N 50/60 Hz

ITEM CODE:

ITEM DESCRIPTION:

MODEL CODE:  
004.50.00023

PAGE:  
10

REVISION:  
01

N°	REF.	DESCRIPTION	QTE.
94	002.50.00026	BRAS DE RINÇAGE EN HAUT OU EN BAS V-K	1
95	002.50.00004	ÉCROU DE BLOCAGE POUR LE BRAS DE RINÇAGE	1
96	002.50.00018	SYSTÈME DE LAVAGE SUPÉRIEUR TUYAU D'ALIMENTATION EN INOX	1
97	002.50.00017	SYSTÈME DE LAVAGE DES CONNECTEURS EN PLASTIQUE	1
98	002.50.00020	SYSTÈME DE LAVAGE SUPÉRIEUR MONTANT INOX	1
99	002.50.00030	PULVÉRISATEUR POUR LES BRAS DE LAVAGE SUPÉRIEURS	4
100	002.00.00095	ECROU INOX M4	1
101	002.50.00019	SYSTÈME DE LAVAGE SUPÉRIEUR INOX EN HAUT À GAUCHE	1
102	002.50.00030	PULVÉRISATEUR POUR LES BRAS DE LAVAGE SUPÉRIEURS	4
103	002.00.00095	ECROU INOX M4	1

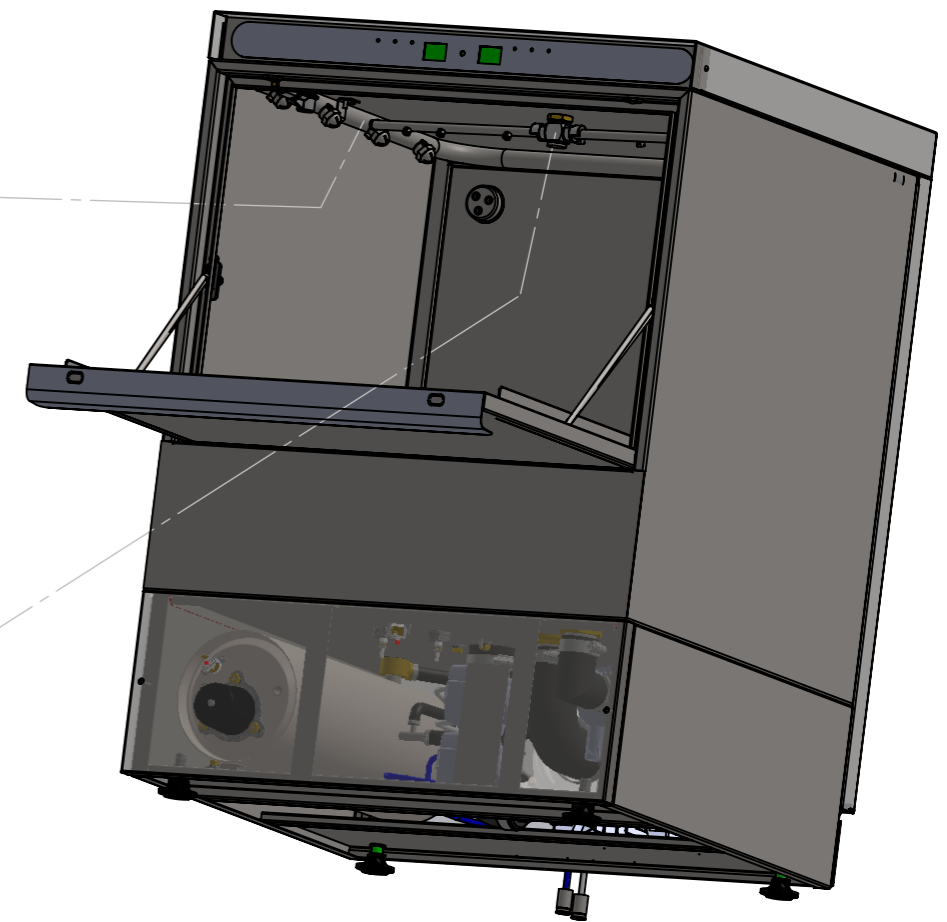
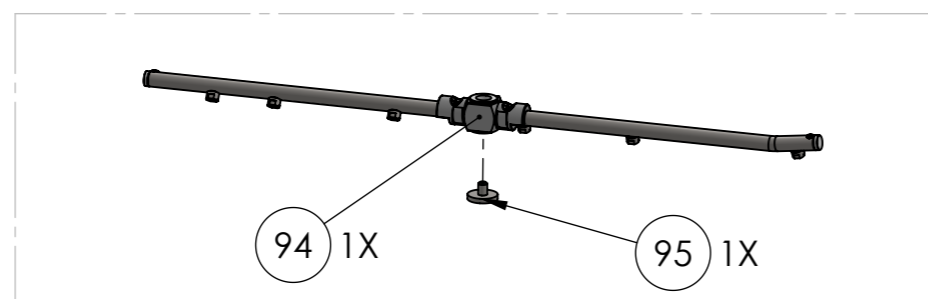
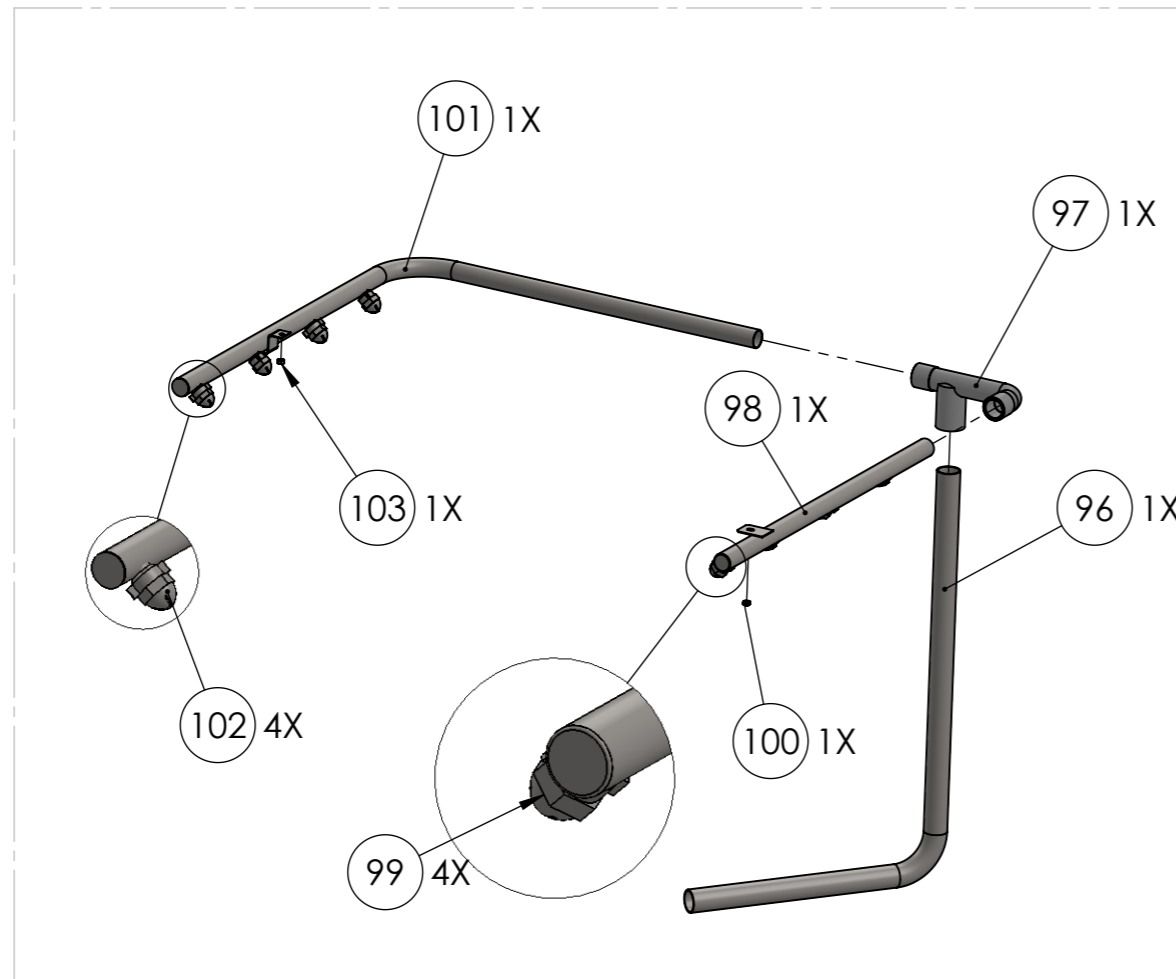

ITEM CODE:	ITEM DESCRIPTION:
MODEL CODE: 004.50.00023	PAGE: 11
	REVISION: 01

SERIES DESCRIPTION:  
LAVE-VAISSELLE

MODEL DESCRIPTION:  
D-LV50-A3P

MODEL VERSION:  
220-240V 1~N 50/60 Hz

N°	REF.	DESCRIPTION	QTE.
104	002.50.00005 (B)	BRAS DE RINCAGE SEUL - B	1
105	002.50.00005 (A)	BRAS DE RINCAGE - A	1
106	002.00.00230	TEFLON $\Phi$ 18X6	2
107	002.11.00008	SPRAYER FOR RINSING ARM BL,EU,VE,KN,1500	6
108	002.00.00277	BOUCHON POUR BRAS DE RINÇAGE	2
109	001.00.00073	VIS INOX 2,9 X 10	2
110	002.50.00025	BASE PLASTIQUE POUR BRAS DE RINCAGE	1

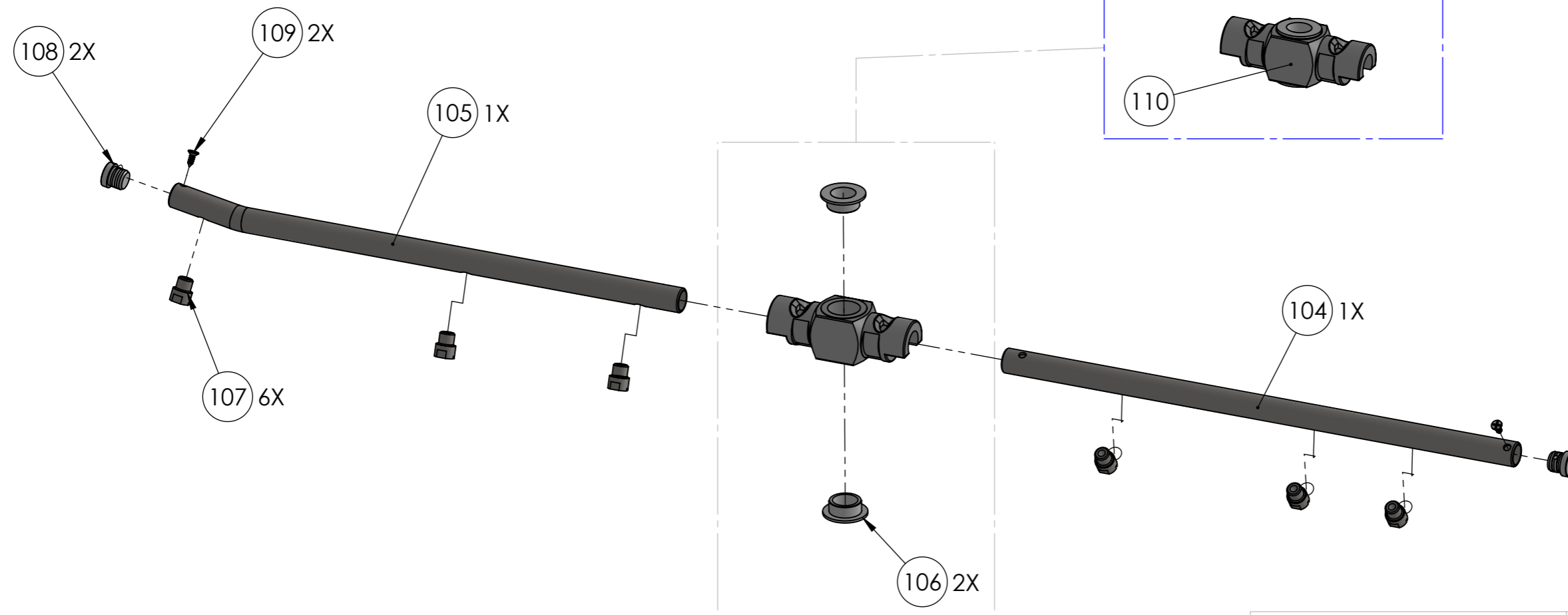

SERIES DESCRIPTION:  
LAVE-VAISSELLE

MODEL DESCRIPTION:  
D-LV50-A3P

MODEL VERSION:  
220-240V 1~N 50/60 Hz

MODEL CODE:  
004.50.00023

PAGE:  
12

REVISION:  
01

ITEM CODE:

ITEM DESCRIPTION:

N°	REF.	DESCRIPTION	QTE.
111	001.00.00051	ENSEMBLE DE PORTES	2
112	003.00.00231	INTERRUPTEUR DE PORTE MECH. PART	1
113	003.00.00489	JOINT D'ÉTANCHÉITÉ EN CAOUTCHOUC 16X30X3	1
114	003.00.00071	ÉCROU POUR INTERRUPTEUR DE PORTE	1

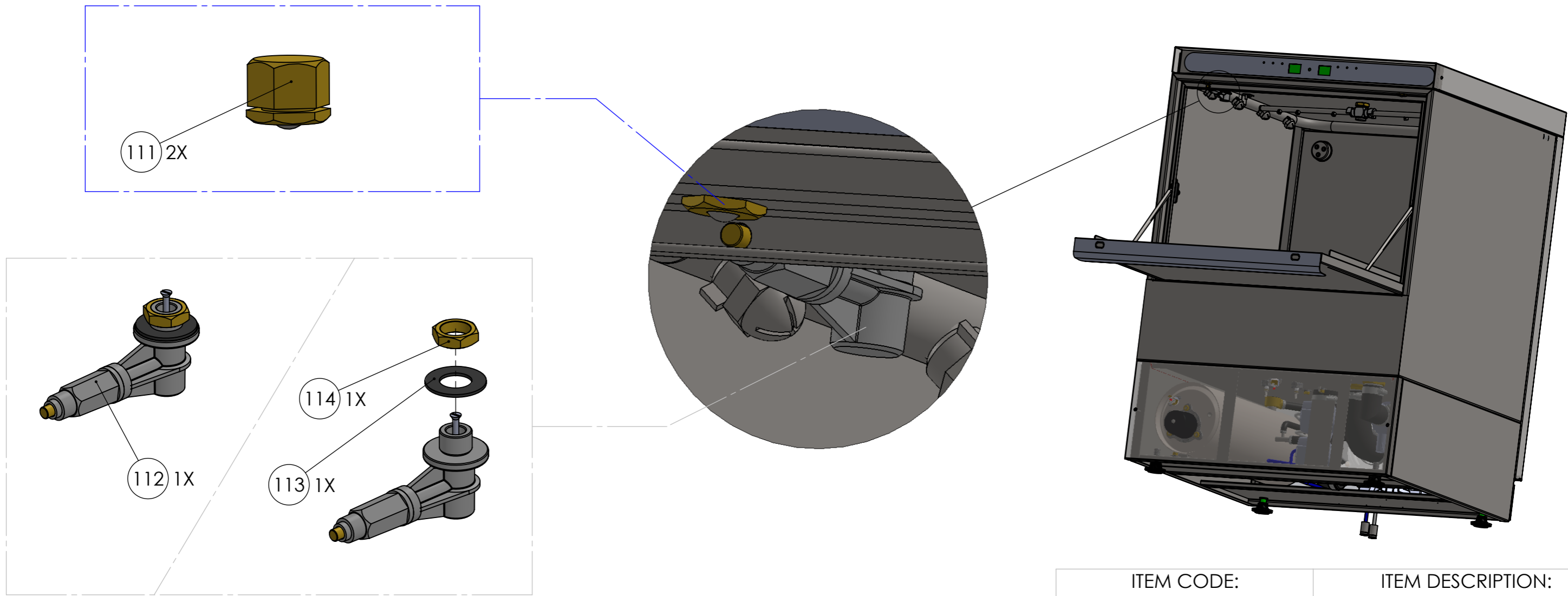

ITEM CODE:	ITEM DESCRIPTION:
MODEL CODE: 004.50.00023	PAGE: 13
	REVISION: 01

SERIES DESCRIPTION: LAVE-VAISSELLE	MODEL DESCRIPTION: D-LV50-A3P	MODEL VERSION: 220-240V 1~N 50/60 Hz
---------------------------------------	----------------------------------	---

N°	REF.	DESCRIPTION	QTE.
115	003.50.00008	RÉSERVOIR DE L'ÉLÉMENT CHAUFFANT 2,8 kW / 230V	1
116	002.00.00100	JOINT 14X3.5	2
117	003.00.00074	ECROU 14 (GALV.)	2
118	003.00.00014	CHAMBRE PRESSOSTATIQUE	1
119	002.00.00087	ECROU M10	1
120	002.00.00091	JOINT 3X10,5	1

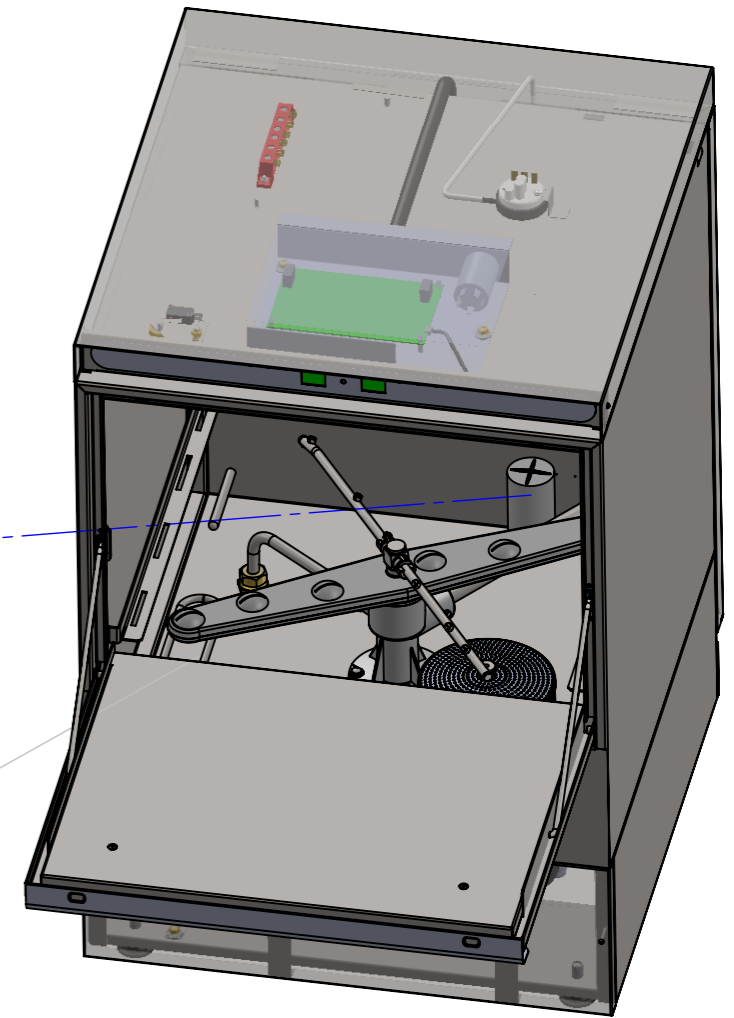
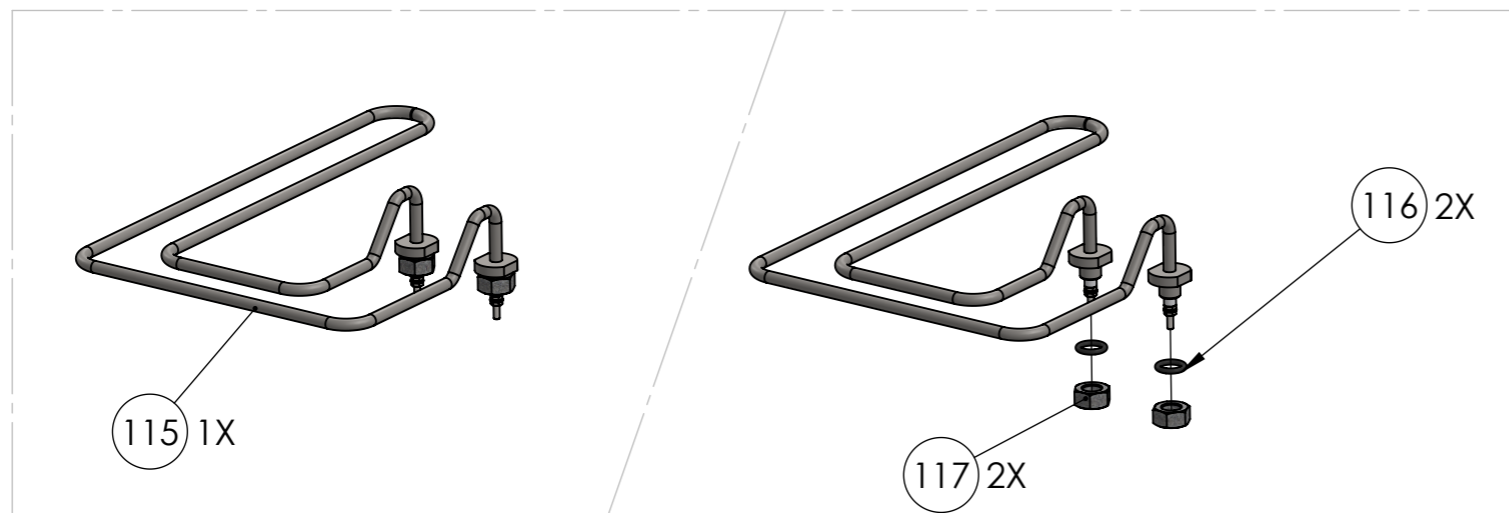
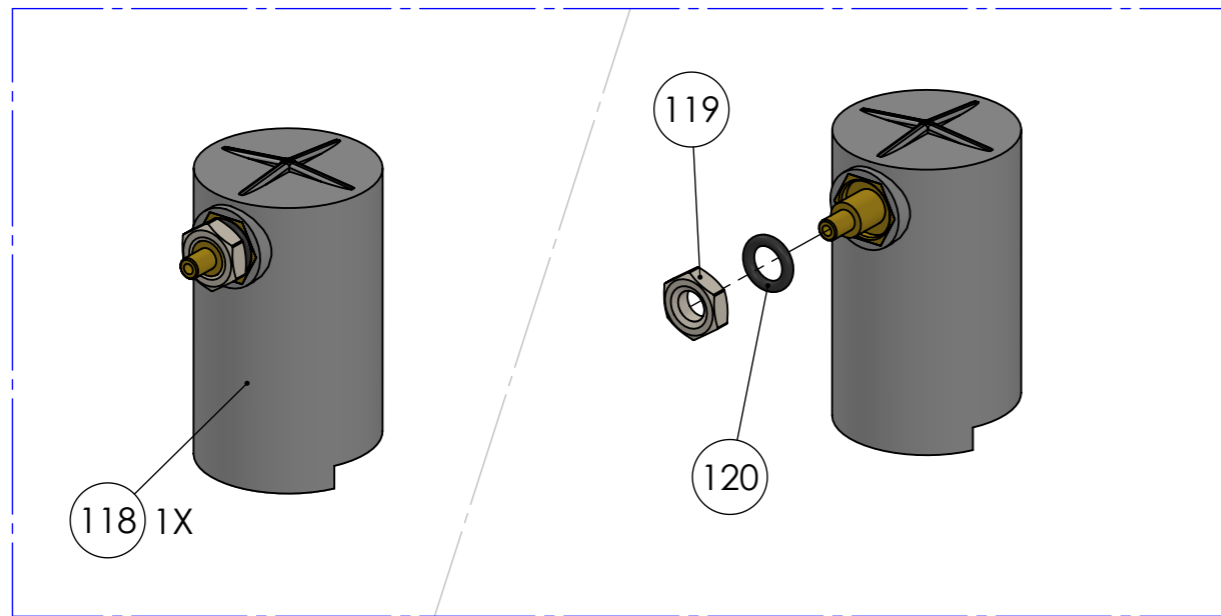

ITEM CODE:	ITEM DESCRIPTION:
MODEL CODE: 004.50.00023	PAGE: 14
	REVISION: 01

SERIES DESCRIPTION:  
LAVE-VAISSELLE

MODEL DESCRIPTION:  
D-LV50-A3P

MODEL VERSION:  
220-240V 1~N 50/60 Hz

N°	REF.	DESCRIPTION	QTE.
121	001.50.00040	FILTRE DE LA POMPE DE VIDANGE V500	1
122	001.70.00000	FILTRE DANS LE RÉSERVOIR POUR LA POMPE V-KN	1
123	001.00.00017	ÉCROU DE RETENUE DU FILTRE	1
124	002.00.00081	BASE EN PLASTIQUE POUR FILTRE DE RÉSERVOIR V-K	1
125	002.00.00093	JOINT 52X2,5	1
126	002.00.00037	ECROU 1 1/2"	1
127	002.00.00257	SOUPAPE DE VIDANGE ET DE TROP-PLEIN BASE EN PLASTIQUE	1
128	002.00.00238	JOINT D'ÉTANCHÉITÉ EN CAOUTCHOUC 35X55X1	1
129	002.00.00133	ECROU BRONZE M36	1
130	002.50.00037	SOUPAPE DE VIDANGE ET DE TROP-PLEIN PIÈCE EN PLASTIQUE NOUVEAU V-K	1

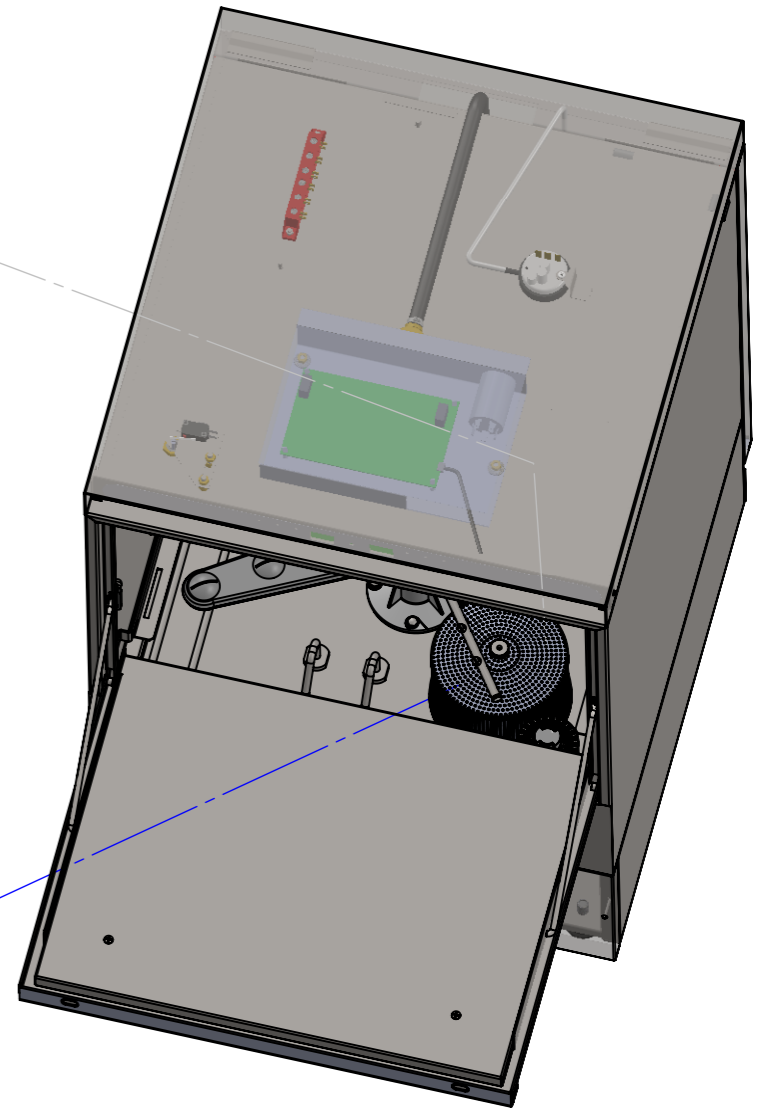
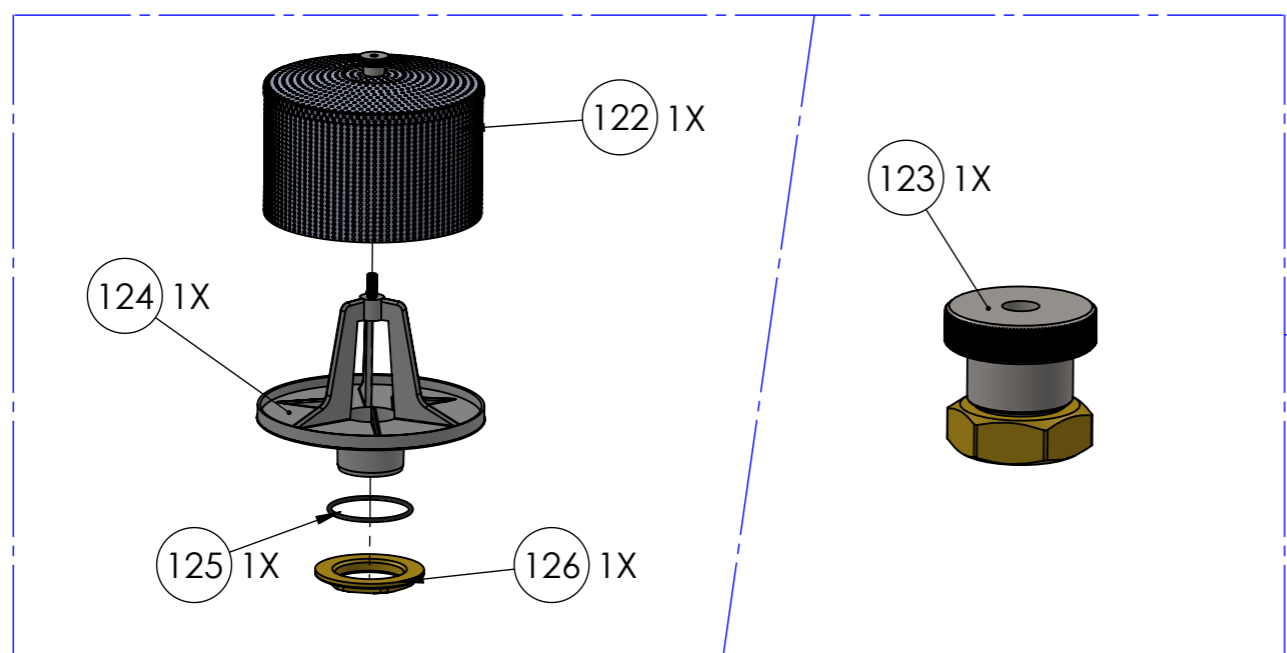
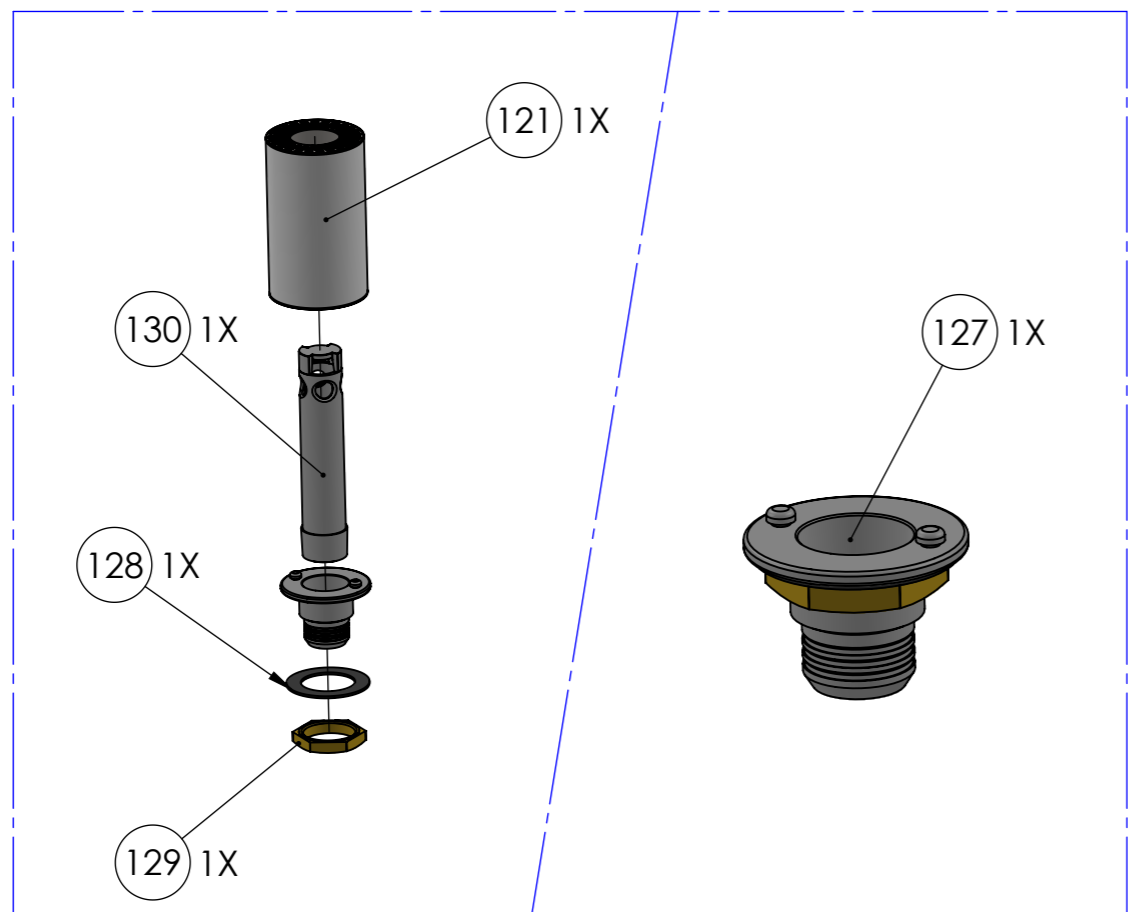

ITEM CODE:	ITEM DESCRIPTION:
MODEL CODE: 004.50.00023	PAGE: 15
	REVISION: 01

SERIES DESCRIPTION:  
LAVE-VAISSELLE

MODEL DESCRIPTION:  
D-LV50-A3P

MODEL VERSION:  
220-240V 1~N 50/60 Hz

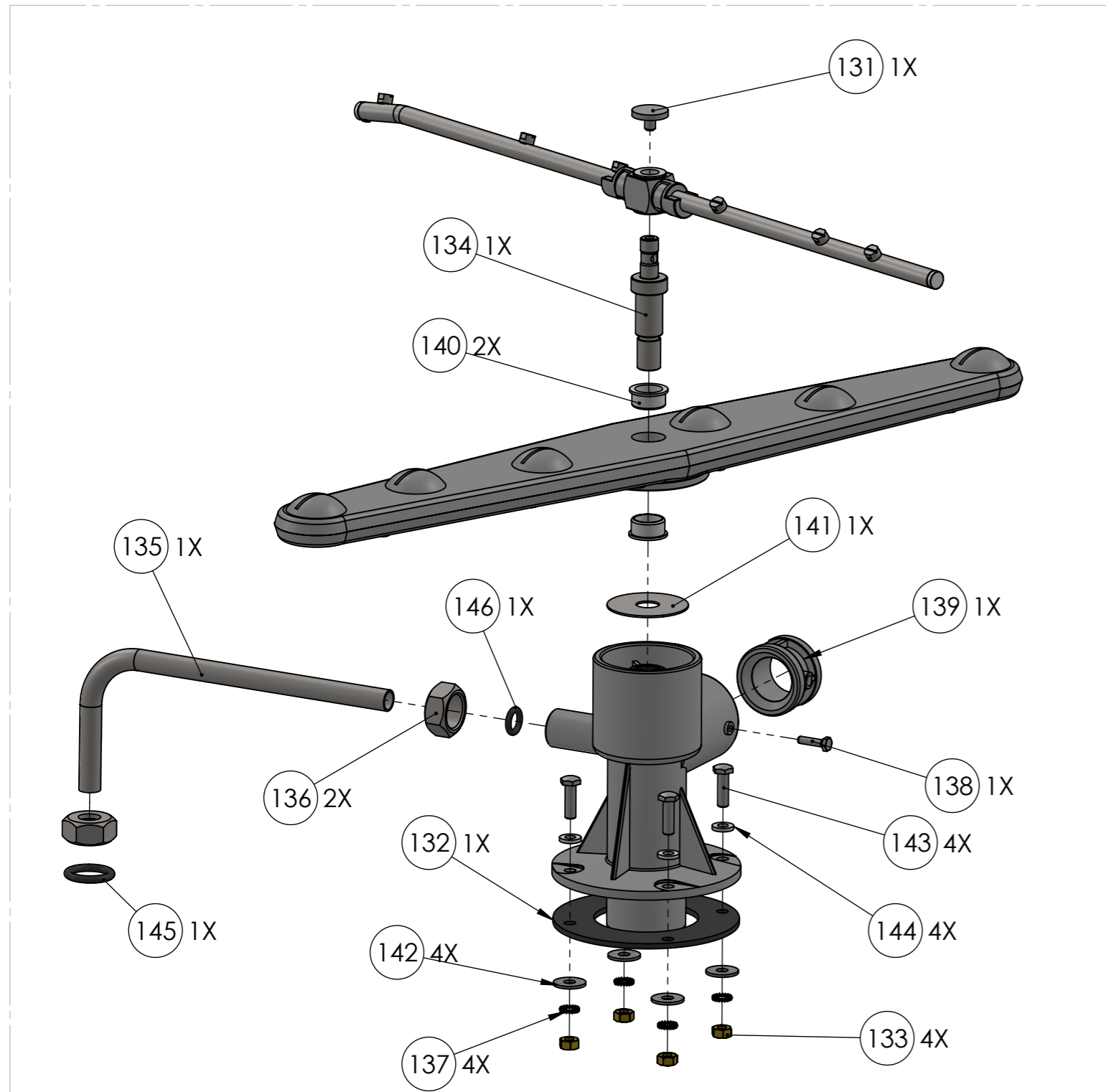

N°	REF.	DESCRIPTION	QTE.
131	002.50.00004	ECROU DE SERRAGE POUR BRAS DE RINCAGE	1
132	002.00.00105	JOINT D'ÉTANCHÉITÉ EN CAOUTCHOUC 103X58X3	1
133	003.00.00041	ECROU M6 GALVANISE	4
134	002.11.00002	ESSIEU INOX POUR BASE EN BAS V500	1
135	002.50.00022	RINSE PIPE INOX V-K	1
136	002.00.00144	ECROU DE MAINTIEN POUR LE TUYAU DE RINCAGE	2
137	001.00.00204	RONDELLE DE SÉCURITÉ GALVANISÉE 6,4x11x0,7	4
138	003.00.00106	BOULON HEXAGONIQUE EN INOX M4X15	1
139	002.50.00024	ADAPTATEUR $\Phi$ 40-25 POUR BASE DE LAVAGE	1
140	002.00.00229	TEFLON $\Phi$ 23X10	2
141	002.50.00016	DISQUE DE CONTRÔLE DE FLUX POUR LA BASE V-K	1
142	003.00.00516	RONDELLE ACIER $\Phi$ 6X18	4
143	003.00.00104	BOULON HEXAGONIQUE INOX M6X20	4
144	002.00.00169	TEFLON 12-6-2	4
145	002.00.00071	JOINT 20X4	1
146	002.00.00091	JOINT 3X10,5	1

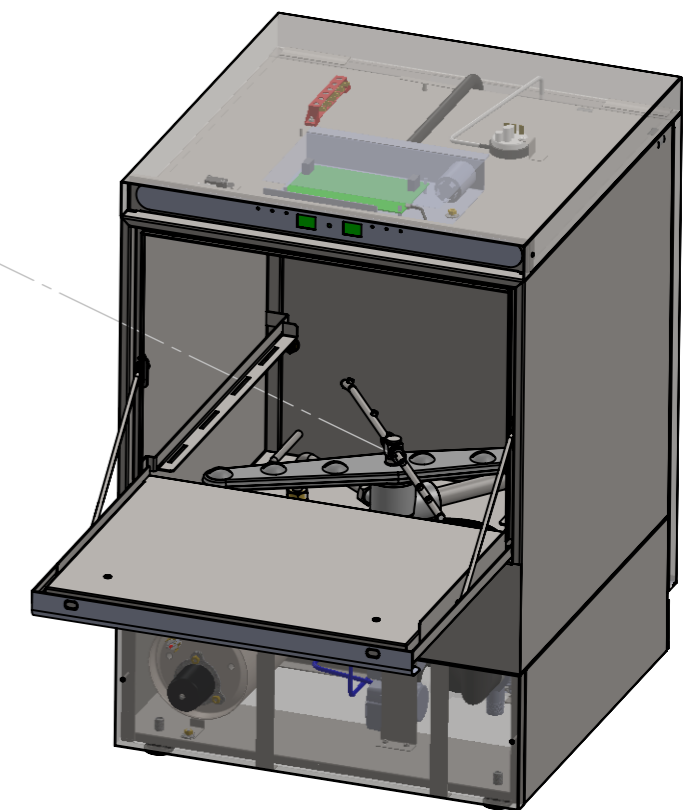

ITEM CODE:	ITEM DESCRIPTION:
MODEL CODE: 004.50.00023	PAGE: 16
	REVISION: 01

SERIES DESCRIPTION:  
LAVE-VAISSELLE

MODEL DESCRIPTION:  
D-LV50-A3P

MODEL VERSION:  
220-240V 1~N 50/60 Hz



N°	REF.	DESCRIPTION	QTE.
147	002.50.00026	BRAS DE RINÇAGE EN HAUT OU EN BAS V-K	1
148	002.50.00036	BASE DE LAVAGE BASSE V-K COMPLETE	1
149	002.50.00006	BRAS DE LAVAGE INFÉRIEUR V50	1

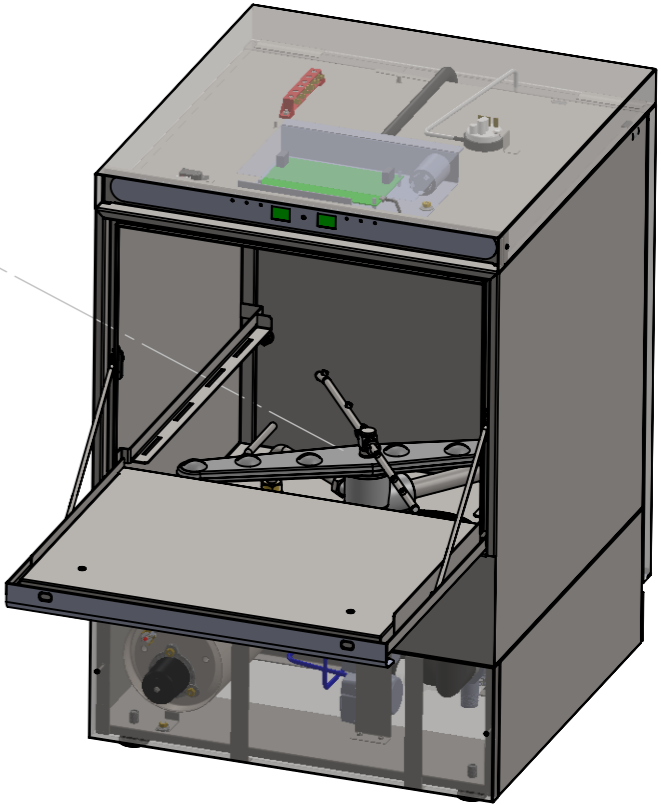
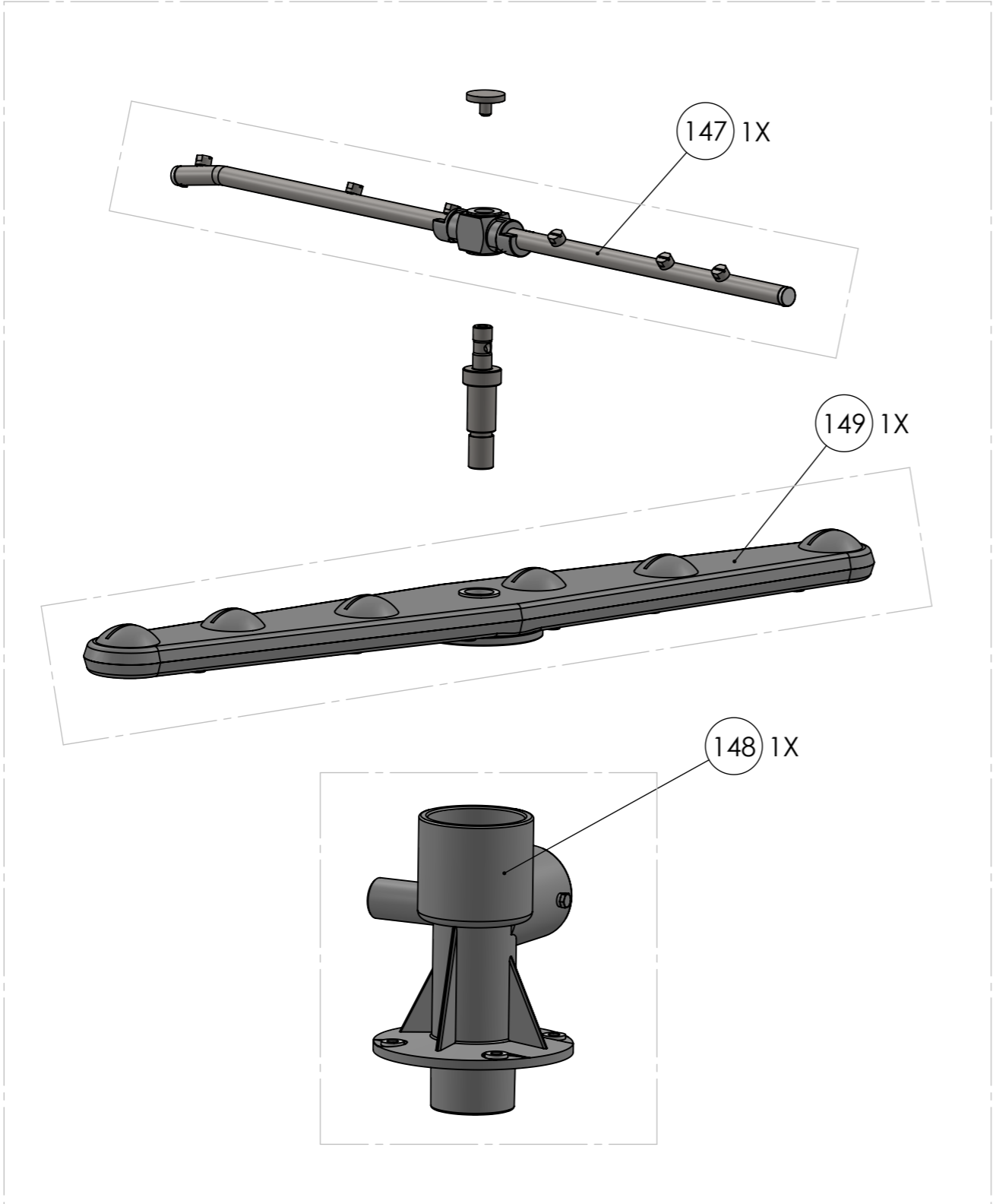

ITEM CODE:	ITEM DESCRIPTION:
MODEL CODE: 004.50.00023	PAGE: 17
	REVISION: 01

SERIES DESCRIPTION:  
LAVE-VAISSELLE

MODEL DESCRIPTION:  
D-LV50-A3P

MODEL VERSION:  
220-240V 1~N 50/60 Hz

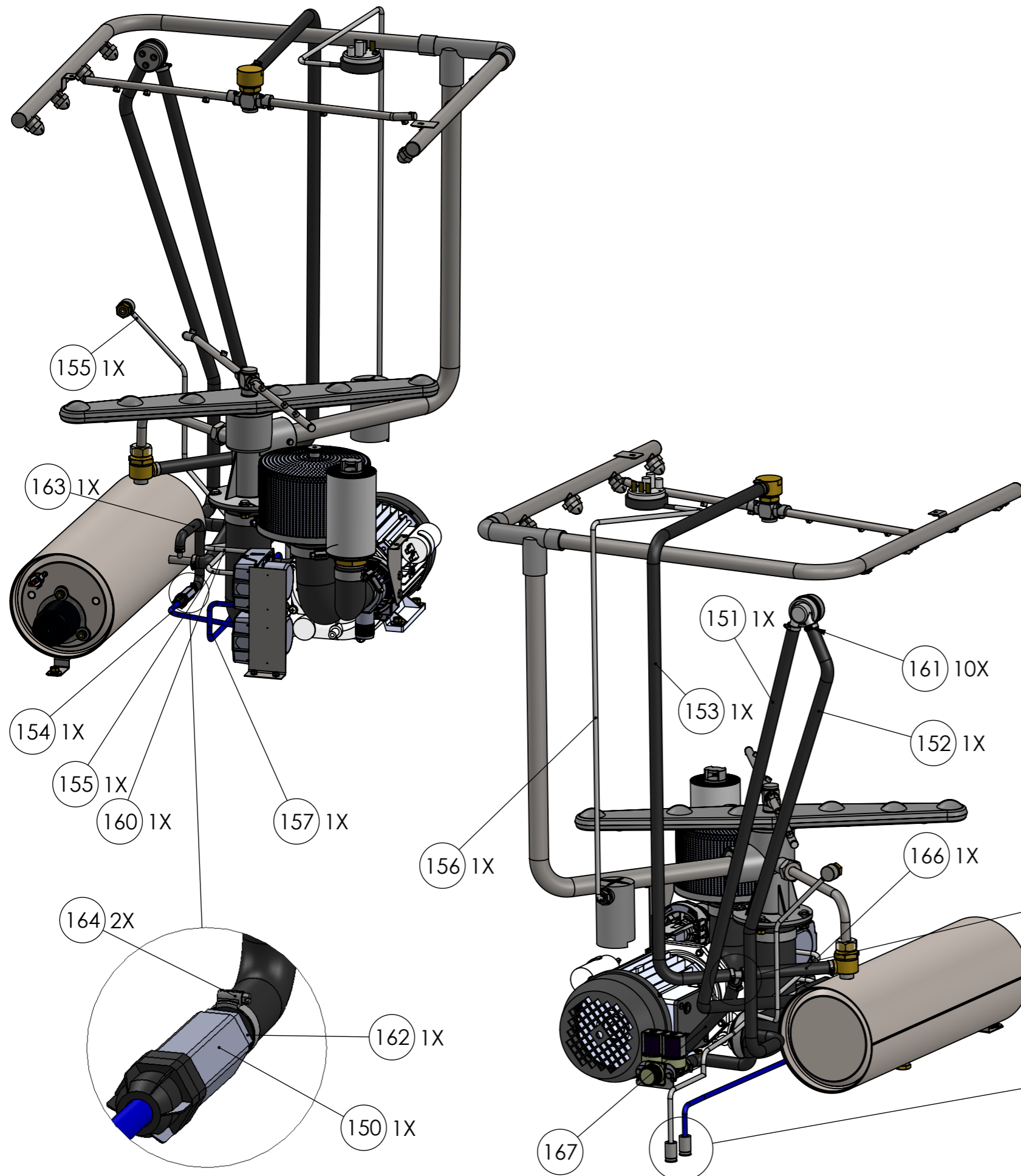

N°	REF.	DESCRIPTION	QTE.
150	002.00.00002	SOUPAPE ANTI-RETOUR POUR LA POMPE D'AIDE AU RINÇAGE	1
151	002.00.00119-14	TUYAU NOIR MACHIE A LAVER 10X16.5	1
152	002.00.00119-12	TUYAU NOIR MACHIE A LAVER 10X16.5	1
153	002.00.00119-15	TUYAU NOIR MACHIE A LAVER 10X16.5	1
154	003.00.00487-6	TUBE PVC BLEU 4X6	1
155	003.00.00140_9	TUBE CRISTAL 4X6	1
156	003.00.00140_8	TUBE CRISTAL 4X6	1
157	003.00.00487-5	TUBE PVC BLEU 4X6	1
158	002.00.00195	BALANCE F15X20	2
159	002.00.00242	FILTRE EN PLASTIQUE POUR LA VANNE D'AIDE AU RINÇAGE	2
160	003.00.00140_10	TUBE CRISTAL 4X6	1
161	002.00.00052	SERRE-JOINT 10-16	10
162	002.00.00287	RACCORDS 1/8x7	1
163	002.00.00132-2	TUYAU NOIR MACHIE A LAVER 6X12	1
164	002.00.00231	SERRE-JOINT 8-12	2
165	002.51.00007	T-CONNECTION BOLIER KNOSSOS	1
166	002.00.00119-16	TUYAU NOIR MACHIE A LAVER 10X16.5	1
167	002.00.00119-17	TUYAU NOIR MACHIE A LAVER 10X16.5	1

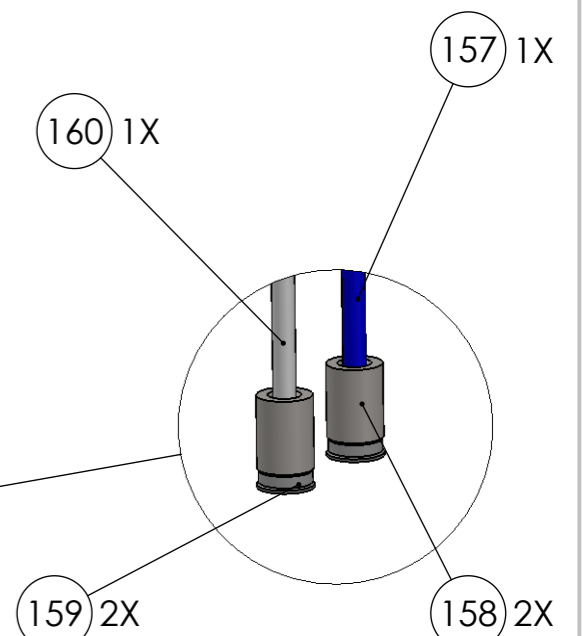
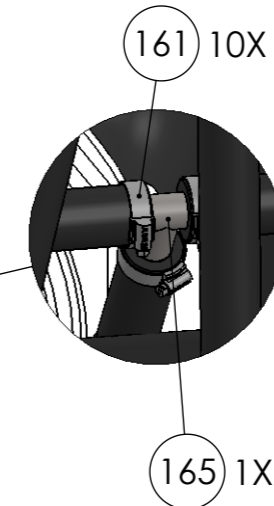

SERIES DESCRIPTION:  
LAVE-VAISSELLE

MODEL DESCRIPTION:  
D-LV50-A3P

MODEL VERSION:  
220-240V 1~N 50/60 Hz

MODEL CODE:  
004.50.00023

PAGE:  
18

REVISION:  
01

ITEM CODE:

ITEM DESCRIPTION: